

Nitrogen Gas Extraction Unit System type

NSF H1

# NSU Series

Easily and stably supplying nitrogen gas.

- Nitrogen gas is obtained just by piping to a pneumatic source.
- All-in-one design with superior installation performance.



## Specifications

Item		NSU-3S	NSU-3L	NSU-4S	NSU-4F	NSU-4L	NSU-4G	NSU-4H		
Range of working conditions	Working fluid	Compressed air								
	Inlet air pressure MPa	0.4 to 1.0 (*1)								
	Proof pressure MPa	1.5								
	Inlet air temperature °C	5 to 50								
	Relative humidity of inlet air RH	50%								
	Ambient temperature °C	5 to 50								
	Inlet air pressure dew point °C	10								
Rating	Inlet air pressure MPa	0.7								
	Inlet air temperature °C	25								
	Ambient temperature °C	25								
Rated flow rate	Outlet nitrogen gas flow rate L/min(ANR) (*2)	Nitrogen concentration (%) or higher	99.9	1.9	5.6	11.0	20.9	30.6	31.9	49.0
			99	5.0	15.5	28.2	53.6	66.9	81.8	107.0
			97	8.9	28.7	49.9	94.8	118.1	159.7	189.0
			95	14.0	39.8	65.3	124.1	169.2	222.0	270.7
			90	27.0	78.1	137.3	260.9	313.5 (*4)	- (*5)	
	Inlet air flow rate L/min(ANR)	Nitrogen concentration (%) or higher	99.9	17.3	50.9	100.0	190.0	278.2	290.0	445.5
			99	20.9	64.6	117.5	223.3	278.8	340.8	445.8
			97	24.1	77.6	134.9	256.2	319.2	431.6	510.8
			95	31.2	88.5	145.2	275.8	376.0	493.3	601.6
			90	60.0	173.6	305.1	579.7	696.7 (*4)	- (*5)	
Air filter	Filtration rating μm	5								
Oil mist filter	Oil removal mg/m <sup>3</sup>	0.01Less than or equal to (0.1 or less after oil saturation) * Primary oil measurement concentration 30mg/m <sup>3</sup> and 21°C.								
Regulator	Set pressure range MPa	0.05 to 0.85								
Oxygen monitor		Refer to page 15 for the specifications.								
Flow rate sensor		Refer to page 17 for the specifications.								
Needle valve	Flow characteristics	Refer to page 4.								
Standard accessories		Pressure gauge/differential pressure gauge/bracket								

\*1: The inlet air pressure when NS-QFS-E is assembled is 0.4 to 0.75MPa.

\*2: When the membrane unit size "H" is selected and the inlet temperature is set to 50°C, the outlet flow rate with nitrogen gas concentration of 99.9% must be 39 L/min or less. Contact CKD when working beyond the specified range.

\*3: Refer to the outlet nitrogen gas flow rate and the needle valve flow characteristics to confirm that the value is within the working range. Contact CKD when working outside the specified range.

\*4: When the "L" sized membrane unit is selected and the outlet nitrogen gas with a concentration of 90% is used, the inlet air temperature should be 40 °C or less. Please contact CKD if you intend to use the product above 40 °C.

\*5: When the "G" and "H" membrane sized units are selected, please contact us if you want to use the outlet nitrogen gas with a concentration of 90%.

## Selection guide

The temperature and inlet air pressure affect the outlet nitrogen gas flow and should be corrected if they differ from the ratings in the specification section.

### STEP 1 Confirm working conditions

Outlet nitrogen gas flow rate [L/min (ANR)]

Outlet nitrogen gas pressure [MPa]

Inlet air pressure [MPa]

Inlet air temperature [°C]

### STEP 2 Confirm the compensation coefficient for outlet nitrogen gas flow rate affected by inlet air temperature.

(1) Temperature - Gas flow rate compensation coefficient

Temp° (°C)	Outlet nitrogen gas concentration				
	99.9%	99%	97%	95%	90%
5	0.64	0.79	0.79	0.75	0.78
10	0.73	0.84	0.84	0.81	0.84
25	1	1	1	1	1
35	0.97	1.05	1.04	1.07	1.07
40	0.95	1.08	1.06	1.11	1.11
50	0.9	1.09	1.11	1.15	1.2

### STEP 3 Confirm the compensation coefficient for outlet nitrogen gas flow rate affected by inlet air pressure.

(2) Pressure - Gas flow rate compensation coefficient

Pressure(MPa)						
0.4	0.5	0.6	0.7	0.8	0.9	1.0
0.4	0.65	0.75	1	1.07	1.2	1.3

### STEP 4 Find the appropriate body size and membrane unit size based on the rated outlet nitrogen gas flow rate of each model.

Rated outlet nitrogen gas flow rate × (1) Temperature gas flow rate correction coefficient × (2) Pressure gas flow rate correction coefficient = corrected refined nitrogen gas flow rate. Select the body size and membrane unit size whose refined nitrogen gas flow rate after correction with the above formula is sufficient for the required gas flow rate

### STEP 5 Select the required needle valve according to the outlet nitrogen gas flow rate.

Based on the outlet nitrogen gas flow and outlet nitrogen gas pressure confirmed in STEP1, select the needle valve from the needle valve flow characteristics (page 4)

### STEP 6 Select the model from STEP4 and STEP5.

### STEP 7 Confirm the compensation coefficient for inlet air flow rate affected by inlet air temperature.

(3) Temperature - Air flow rate compensation coefficient

Temp (°C)	Outlet nitrogen gas concentration				
	99.9%	99%	97%	95%	90%
5	0.73	0.68	0.75	0.69	0.76
10	0.8	0.76	0.81	0.77	0.82
25	1	1	1	1	1
35	1.21	1.17	1.11	1.13	1.11
40	1.32	1.25	1.17	1.2	1.16
50	2.05	1.38	1.31	1.31	1.3

### STEP 8 Confirm the compensation coefficient for inlet air flow rate affected by inlet air pressure.

(4) Pressure - Air flow rate compensation coefficient

Pressure(MPa)						
0.4	0.5	0.6	0.7	0.8	0.9	1.0
0.61	0.79	0.91	1	1.07	1.2	1.3

### STEP 9 Find the inlet air flow rate from the rated outlet nitrogen gas flow rate of each model.

Inlet air flow rate of the model selected in STEP4 × (3) temperature air flow rate correction coefficient × (4) pressure air flow rate correction coefficient = corrected inlet air flow rate. Based on the inlet air flow rate corrected as above, confirm whether the compressor capacity is sufficient.

Example of calculation

Conditions	Working conditions	Selecting conditions	Compensation coefficient for outlet nitrogen gas flow rate	Compensation coefficient for inlet air flow rate
Outlet nitrogen concentration	99 [%]	99 [%]	-	-
Outlet nitrogen pressure	0.2 [MPa]	0.2 [MPa]	-	-
Inlet air temperature	35 [°C]	35 [°C]	(1) 1.05	(3) 1.17
Inlet air pressure	0.6 to 0.7 [MPa]	0.6 [MPa]	(2) 0.75	(4) 0.91

Substitute the above conditions into the equation above to obtain the outlet nitrogen gas flow rate when using the NSU-4L / at a nitrogen concentration of 99%.

66.9 (rated outlet nitrogen gas flow rate) × 1.05 × 0.75 = 52.7L/min (ANR).

If the required nitrogen gas flow rate is less than or equal to this value, select that model.

In this case, the inlet air flow rate is 278.8 × 1.17 × 0.91 = 296.8L/min (ANR).

For needle size, select NS-QDVL-160 at 0.2MPa, which can be adjusted at 53L/min (ANR).

## How to order

NSU - **4** **S** **A** **10A** **NN** - **N** **T** - **FP1**

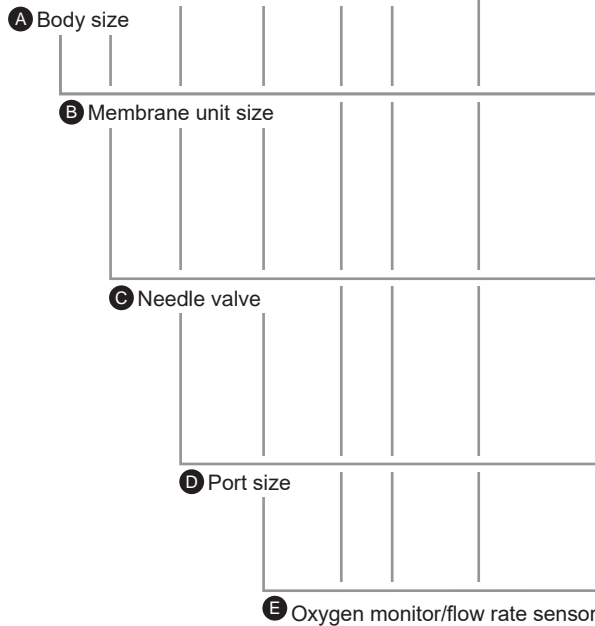

\*The oxygen sensor does not include connector cables. Order the following connector cable discrete model No.

Connector cable discrete model No.

- DC cable
- AC adapter single unit

<b>PNA-1D</b>	<b>PNA-A</b>
<b>Cable length</b>	<b>AC adapter + conversion plug set</b>
1D 1000 mm	<b>PNA-AG</b>
3D 3000 mm	
5D 5000 mm	

Refer to page 16 for dimensions.

### ⚠ Precautions for model No. selection

- \*1: Only the body size "4" is available for the membrane unit sizes "F", "G" and "H".
- \*2: Refer to the table below for combinations of **C** needle valve. Select a flow rate sensor with a suitable range for the needle valve.

	Needle valve size NS-QDVL-***				
	20	80	160	240	400
NSU-3S	A	B			
NSU-3L	A	B	C		
NSU-4S/4F	A	B	C	D	
NSU-4L/4G/4H	A	B	C	D	E

- \*3: When selecting G3/8, the regulator pressure gauge units will be shown as bar.
- \*4: When selecting NPT3/8, the regulator pressure gauge units will be shown as psi.
- \*5: Switch output for the flow rate sensor is NPN. Specify the option "P" to obtain PNP output.
- \*6: Exhaust air (oxygen-enriched gas) from standard products is released into the atmosphere. For "E", piping connection for exhaust (oxygen-rich gas) is possible. Size of exhaust port is Rc1/2.
- \*7: Viewed from the front, standard products have an air inlet on the left port and a nitrogen gas outlet on the right port.

Code	Description
<b>A Body size</b>	
3	Body width 63
4	Body width 79
<b>B Membrane unit size (*1)</b>	
S	Short
F	Short + Short
L	Long
G	Long + Short
H	Long + Long
<b>C Needle valve (*2)</b>	
A	Max. flow rate 20 L/min
B	Max. flow rate 80L/min
C	Max. flow rate 160 L/min
D	Max. flow rate 240 L/min
E	Max. flow rate 400 L/min
<b>D Port size</b>	
10A	Rc3/8
10B	G3/8 (*3)
10C	NPT3/8 (*4)
<b>E Oxygen monitor/flow rate sensor (*5)</b>	
NN	No
AK	With oxygen monitor
AM	With oxygen monitor, traceability cert with series variation diag and company cert
BA	With flow rate sensor (20 L/min specification)
BB	With flow rate sensor (50 L/min specification)
BC	With flow rate sensor (100 L/min specification)
BD	With flow rate sensor (200 L/min specification)
BE	With flow rate sensor (500 L/min specification)
CA	With oxygen monitor and flow rate sensor (20 L/min specification)
CB	With oxygen monitor and flow rate sensor (50 L/min specification)
CC	With oxygen monitor and flow rate sensor (100 L/min specification)
CD	With oxygen monitor and flow rate sensor (200 L/min specification)
CE	With oxygen monitor and flow rate sensor (500 L/min specification)
CF	With oxygen monitor (with traceability) and flow rate sensor (20 L/min specification)
CG	With oxygen monitor (with traceability) and flow rate sensor (50 L/min specification)
CH	With oxygen monitor (with traceability) and flow rate sensor (100 L/min specification)
CJ	With oxygen monitor (with traceability) and flow rate sensor (200 L/min specification)
CK	With oxygen monitor (with traceability) and flow rate sensor (500 L/min specification)
<b>F Option</b>	
N	No option
E	With exhaust port (*6)
K	Flow rate sensor With unit switching function (overseas models only)
P	Flow rate sensor Switch output: PNP output
X	Reverse flow (*7)
<b>G Mounting direction</b>	
Blank	Vertical mounting
T	Horizontal mounting (available with NSU-4S, 4L)
<b>H Series</b>	
Blank	Standard
FP1	Series for food processing

\* Contact CKD for other combinations.

### Needle valve flow characteristics

\*The flow rate characteristics graph indicates reference values and does not guarantee the values.

● NS-QDVL-020

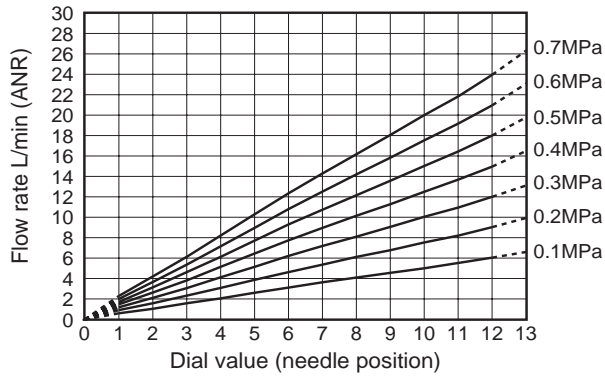

● NS-QDVL-080

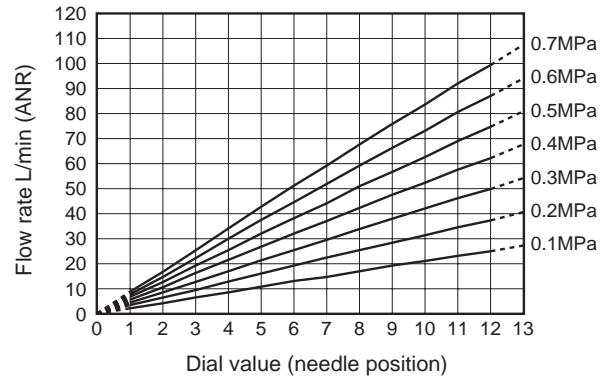

● NS-QDVL-160

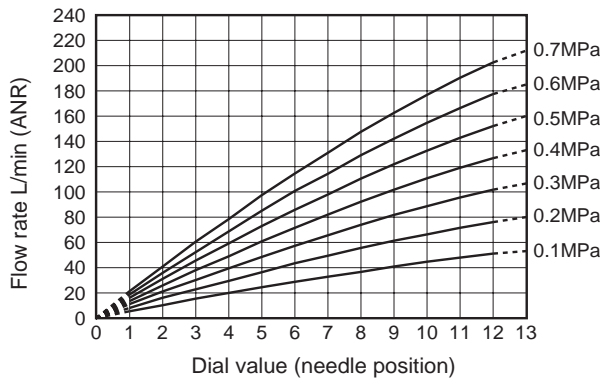

● NS-QDVL-240

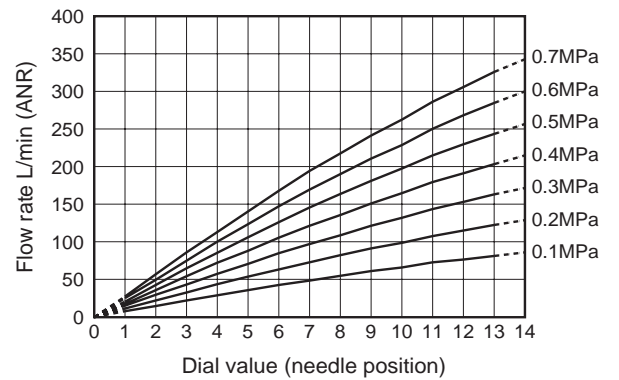

● NS-QDVL-400

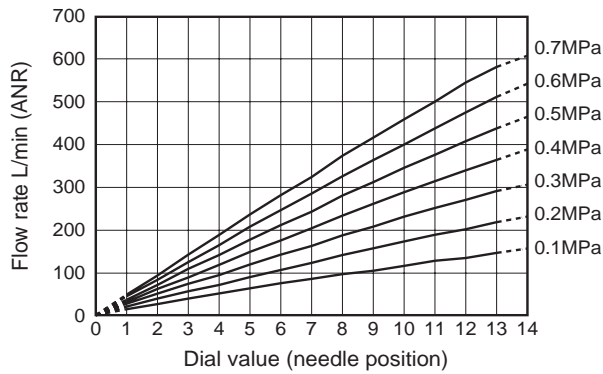

## System components (vertical mount)

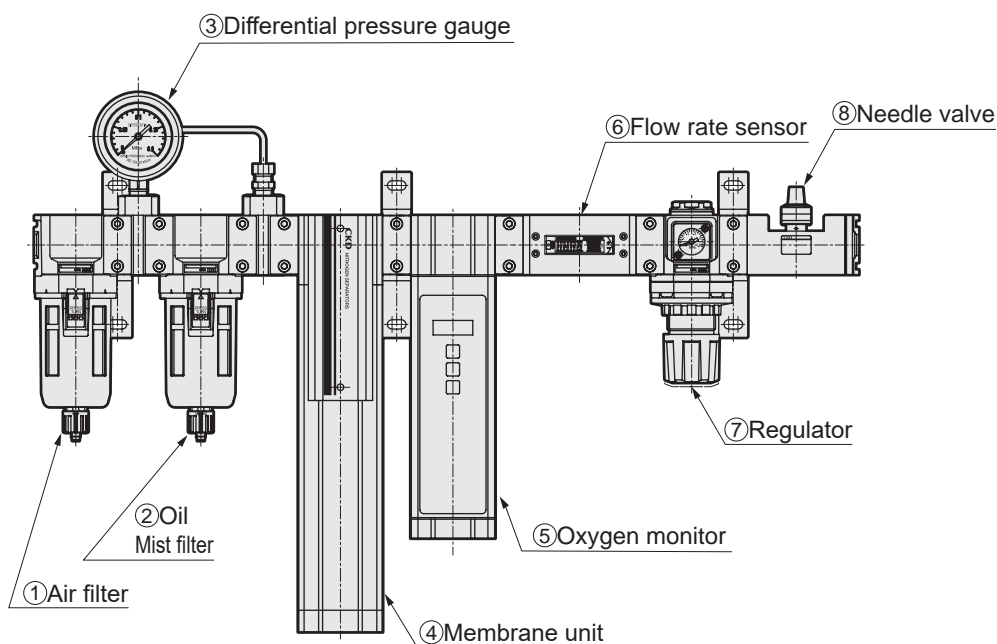

### Standard (with port size Rc3/8)

Unit model No.	NSU-3S□	NSU-3L□	NSU-4S□	NSU-4F□	NSU-4L□	NSU-4G□	NSU-4H□
(1) Air filter	F3000-10-W-F		F4000-10-W-F				
(2) Oil mist filter	M3000-10-W-F1		M4000-10-W-F1				
(3) Differential pressure gauge	GA400-8-P02						
(4) Membrane unit	NS-3S110A-□	NS-3L110A-□	NS-4S110A-□	NS-4S110A-□ NS-4S110A-□	NS-4L110A-□	NS-4L110A-□ NS-4S110A-□	NS-4L110A-□ NS-4L110A-□
(5) Oxygen monitor	PNA-10A-□-FP2						
(6) Flow rate sensor	NS-QFS-□						
(7) Regulator	NS-QR3-FP1			NS-QR4-FP1			
(8) Needle valve	NS-QDVL-020 NS-QDVL-080	NS-QDVL-020 NS-QDVL-080 NS-QDVL-160	NS-QDVL-020 NS-QDVL-080 NS-QDVL-160 NS-QDVL-240	NS-QDVL-020 NS-QDVL-080 NS-QDVL-160 NS-QDVL-240 NS-QDVL-400			

### FP1 (with port size Rc3/8)

Unit model No.	NSU-3S□-FP1	NSU-3L□-FP1	NSU-4S□-FP1	NSU-4F□-FP1	NSU-4L□-FP1	NSU-4G□-FP1	NSU-4H□-FP1
(1) Air filter	F3000-10-W-F-FP1		F4000-10-W-F-FP1				
(2) Oil mist filter	M3000-10-W-F1-FP1		M4000-10-W-F1-FP1				
(3) Differential pressure gauge	GA400-8-P02						
(4) Membrane unit	NS-3S110A-□-FP2	NS-3L110A-□-FP2	NS-4S110A-□-FP2	NS-4S110A-□-FP2 NS-4S110A-□-FP2	NS-4L110A-□-FP2	NS-4L110A-□-FP2 NS-4S110A-□-FP2	NS-4L110A-□-FP2 NS-4L110A-□-FP2
(5) Oxygen monitor	PNA-10A-□-FP2						
(6) Flow rate sensor	NS-QFS-□						
(7) Regulator	NS-QR3-FP1			NS-QR4-FP1			
(8) Needle valve	NS-QDVL-020 NS-QDVL-080	NS-QDVL-020 NS-QDVL-080 NS-QDVL-160	NS-QDVL-020 NS-QDVL-080 NS-QDVL-160 NS-QDVL-240	NS-QDVL-020 NS-QDVL-080 NS-QDVL-160 NS-QDVL-240 NS-QDVL-400			

\*Contact CKD regarding port size G3/8 and NPT3/8.

## System components (horizontal mounting)

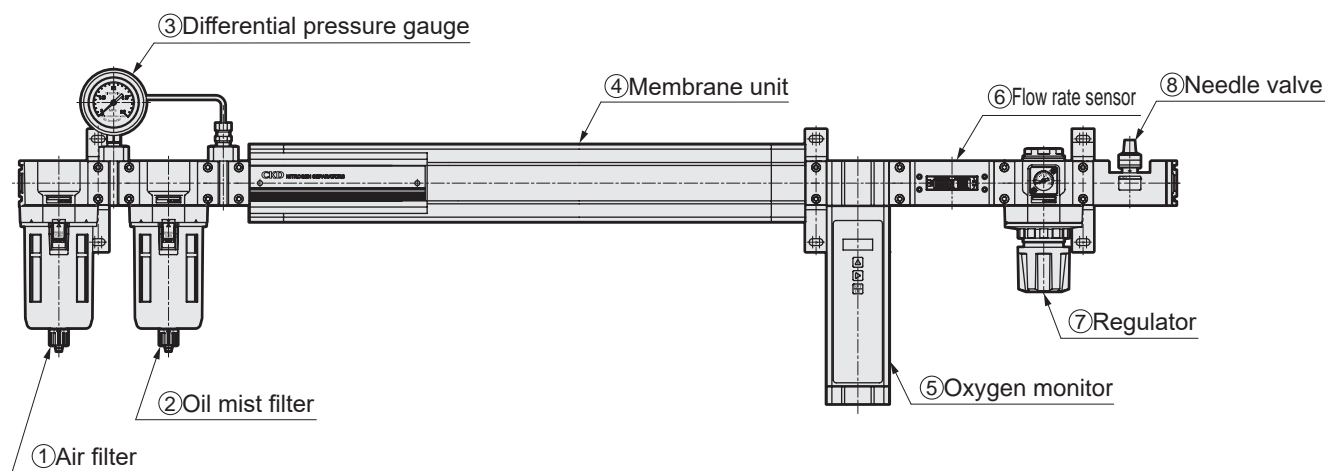

### ■ Standard (with port size Rc3/8)

Unit model No.	NSU-4S□-□T	NSU-4L□-□T
(1) Air filter	F4000-10-W-F	
(2) Oil mist filter	M4000-10-W-F1	
(3) Differential pressure gauge	GA400-8-P02	
(4) Membrane unit	NS-4S110A-□T	NS-4L110A-□T
(5) Oxygen monitor	PNA-10A-□-FP2	
(6) Flow rate sensor	NS-QFS-□	
(7) Regulator	NS-QR4-FP1	
(8) Needle valve	NS-QDVL-020	NS-QDVL-020
	NS-QDVL-080	NS-QDVL-080
	NS-QDVL-160	NS-QDVL-160
	NS-QDVL-240	NS-QDVL-240
		NS-QDVL-400

### ■ FP1 (with port size Rc3/8)

Unit model No.	NSU-4S□-□T-FP1	NSU-4L□-□T-FP1
(1) Air filter	F4000-10-W-F-FP1	
(2) Oil mist filter	M4000-10-W-F1-FP1	
(3) Differential pressure gauge	GA400-8-P02	
(4) Membrane unit	NS-4S110A-□T-FP2	NS-4L110A-□T-FP2
(5) Oxygen monitor	PNA-10A-□-FP2	
(6) Flow rate sensor	NS-QFS-□	
(7) Regulator	NS-QR4-FP1	
(8) Needle valve	NS-QDVL-020	NS-QDVL-020
	NS-QDVL-080	NS-QDVL-080
	NS-QDVL-160	NS-QDVL-160
	NS-QDVL-240	NS-QDVL-240
		NS-QDVL-400

\*Contact CKD regarding port size G3/8 and NPT3/8.

## Dimensions (1-station type)

- Without oxygen monitor/without flow rate sensor (NSU-<sup>3S</sup><sub>4L</sub>\*10\*NN)

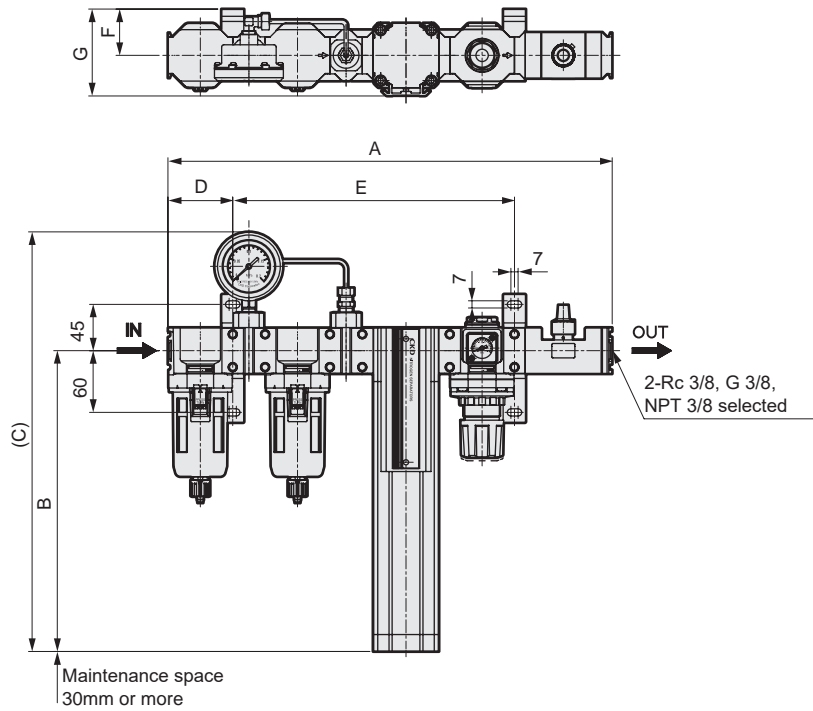

Model No.	A	B	C	D	E	F	G	Weight (kg)
NSU-3S*10*NN	432	293	408	63	274	45	85	4.0
NSU-3L*10*NN	432	543	658	63	274	45	85	4.9
NSU-4S*10*NN	498	543	658	80	323	55	106	6.9
NSU-4L*10*NN	498	1043	1158	80	323	55	106	9.7

- Without oxygen monitor/without flow sensor (NSU-4<sup>S</sup><sub>L</sub>\*10\*NN-\*T)

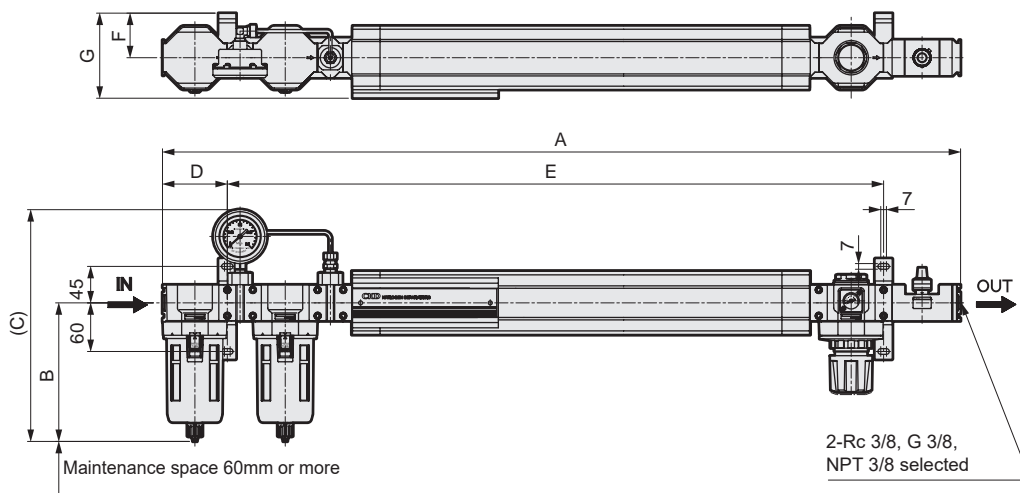

Model No.	A	B	C	D	E	F	G	Weight (kg)
NSU-4S*10*NN-*T	985	171	286	80	810	55	106	7.1
NSU-4L*10*NN-*T	1485	171	286	80	1310	55	106	9.9

## Dimensions

- With oxygen monitor/without flow rate sensor (NSU-<sup>3S</sup><sub>4L</sub>\*10\*A\*)

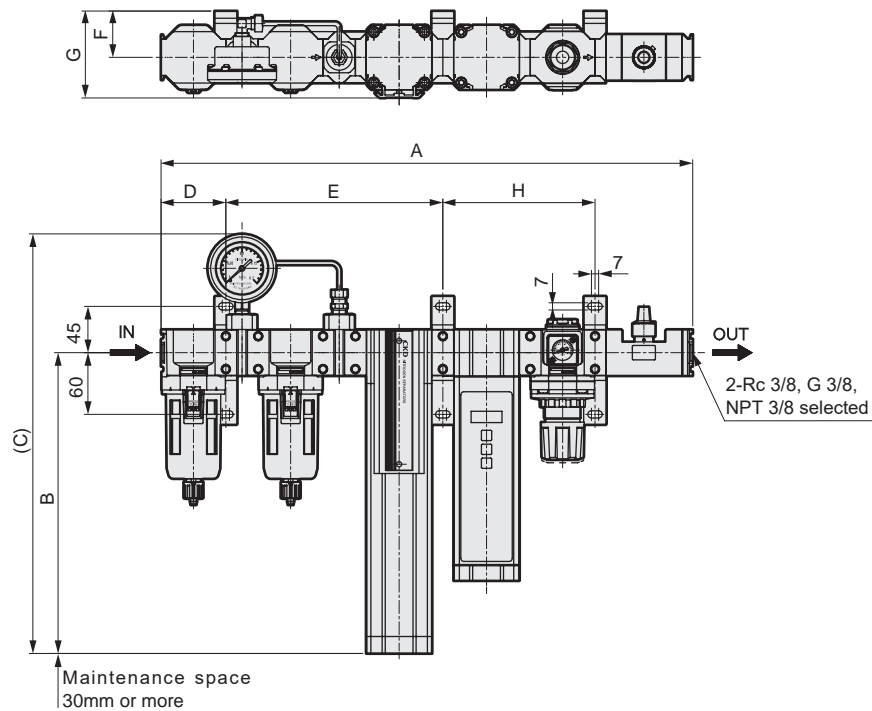

Model No.	A	B	C	D	E	F	G	H	Weight (kg)
NSU-3S*10*A*	517	293	408	63	211	45	85	148	5.6
NSU-3L*10*A*	517	543	658	63	211	45	85	148	6.5
NSU-4S*10*A*	583	543	658	80	243	55	106	165	8.5
NSU-4L*10*A*	583	1043	1158	80	243	55	106	165	11.3

- With oxygen monitor/without flow sensor (NSU-4<sup>S</sup><sub>L</sub>\*10\*A\*-\*T)

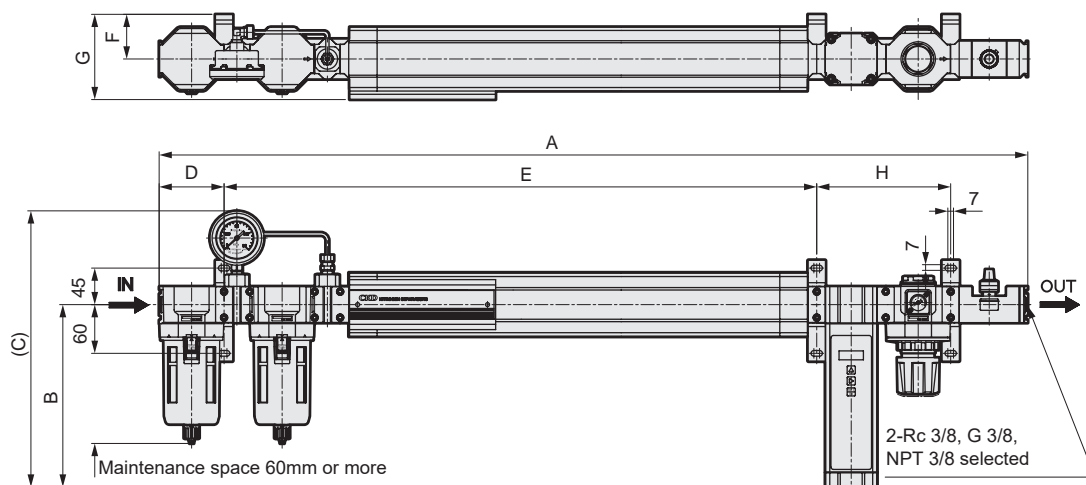

\* You need at least 60mm of wiring space under the oxygen meter.

Model No.	A	B	C	D	E	F	G	H	Weight (kg)
NSU-4S*10*A*-*T	1070	225	340	80	730	55	106	165	8.7
NSU-4L*10*A*-*T	1570	225	340	80	1230	55	106	165	11.5

## Dimensions (1 station)

- Without oxygen monitor/with flow rate sensor (NSU-<sup>3S</sup><sub>4L</sub>\*10\*B\*)

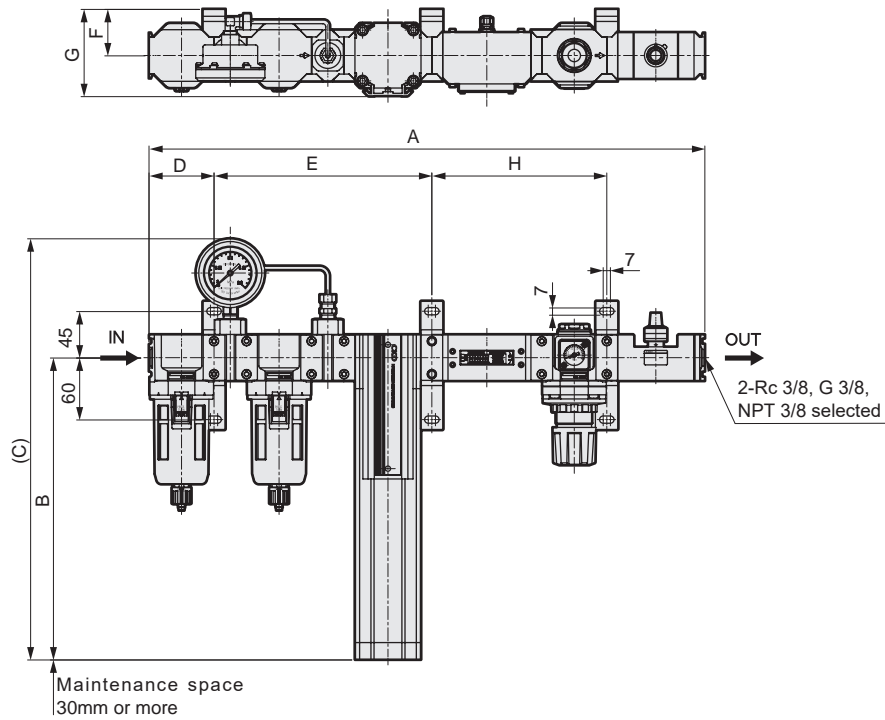

Model No.	A	B	C	D	E	F	G	H	Weight (kg)
NSU-3S*10*B*	538.5	293	408	63	211	45	85	169.5	4.8
NSU-3L*10*B*	538.5	543	658	63	211	45	85	169.5	5.7
NSU-4S*10*B*	604.5	543	658	80	243	55	106	186.5	7.7
NSU-4L*10*B*	604.5	1043	1158	80	243	55	106	186.5	10.5

- Without oxygen monitor/with flow rate sensor (NSU-4<sup>S</sup><sub>L</sub>\*10\*B\*-\*T)

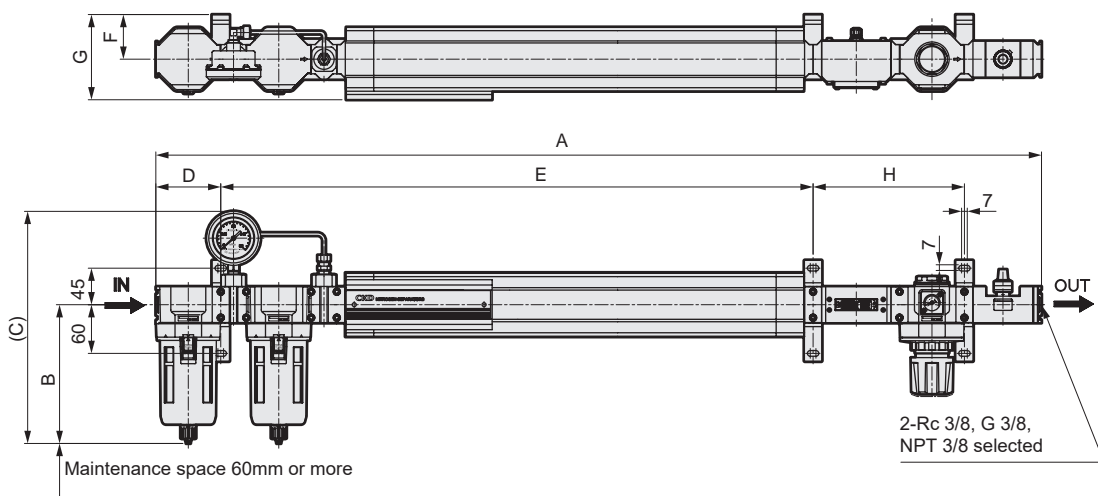

Model No.	A	B	C	D	E	F	G	H	Weight (kg)
NSU-4S*10*B*-*T	1091.5	171	286	80	730	55	106	186.5	7.9
NSU-4L*10*B*-*T	1591.5	171	286	80	1230	55	106	186.5	10.7

## Dimensions (1 station)

- With oxygen monitor/with flow rate sensor (NSU-3S<sub>4L</sub>\*10\*C\*)

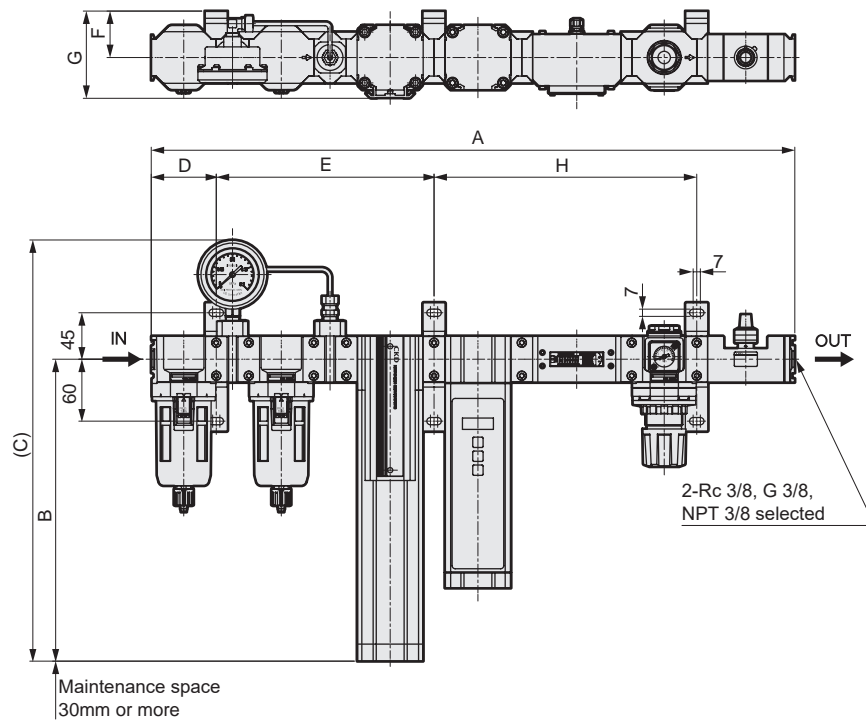

Model No.	A	B	C	D	E	F	G	H	Weight (kg)
NSU-3S*10*C*	623.5	293	408	63	211	45	85	254.5	6.4
NSU-3L*10*C*	623.5	543	658	63	211	45	85	254.5	7.3
NSU-4S*10*C*	689.5	543	658	80	243	55	106	271.5	9.3
NSU-4L*10*C*	689.5	1043	1158	80	243	55	106	271.5	12.1

- With oxygen monitor/with flow rate sensor (NSU-4<sub>L</sub><sup>S</sup>\*10\*C\*-\*T)

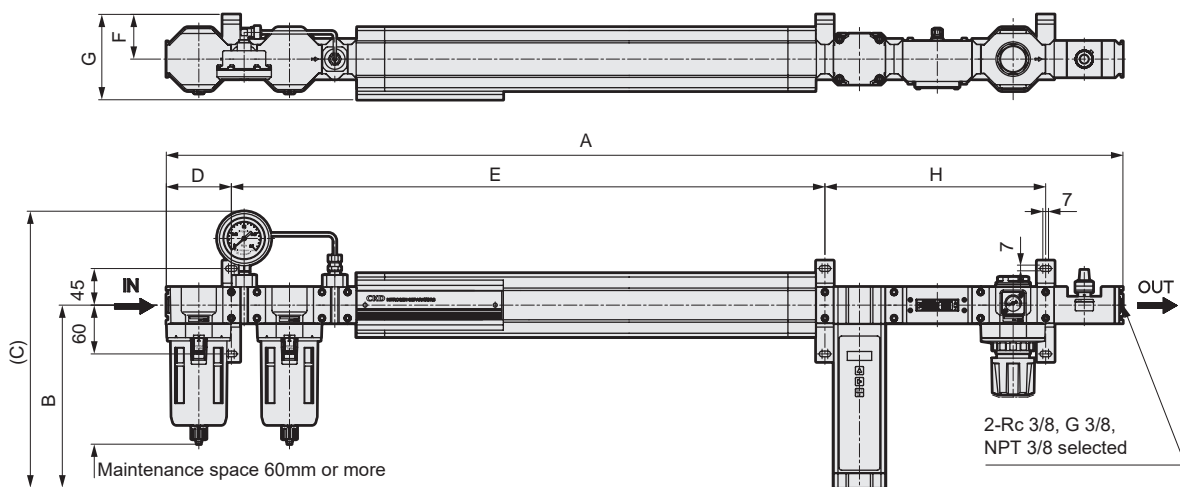

\* You need at least 60mm of wiring space under the oxygen meter.

Model No.	A	B	C	D	E	F	G	H	Weight (kg)
NSU-4S*10*C*-*T	1176.5	225	340	80	730	55	106	271.5	9.5
NSU-4L*10*C*-*T	1676.5	225	340	80	1230	55	106	271.5	12.3

## Dimensions (2-station type)

- No oxygen monitor or flow rate sensor (NSU-4<sup>F</sup><sub>G</sub>\*10\*NN)

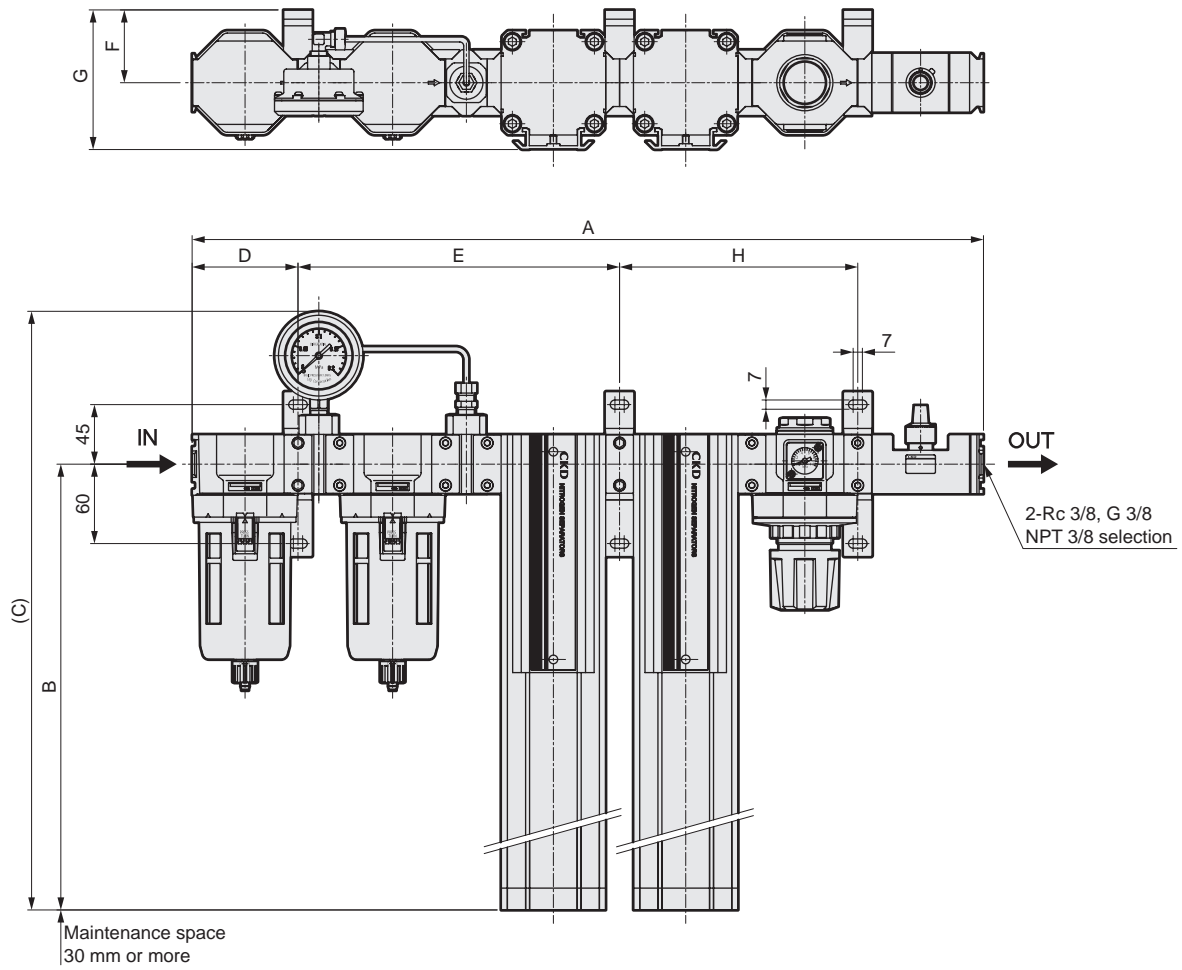

Model No.	A	B	C	D	E	F	G	H	Weight (kg)
NSU-4F*10*NN	598	543	658	80	243	55	106	180	10.9
NSU-4G*10*NN	598	1043	1158	80	243	55	106	180	13.7
NSU-4H*10*NN	598	1043	1158	80	243	55	106	180	16.5

## Dimensions (2-station type)

- With oxygen monitor, no flow rate sensor (NSU-4<sup>F</sup><sub>G</sub>\*10\*A\*)

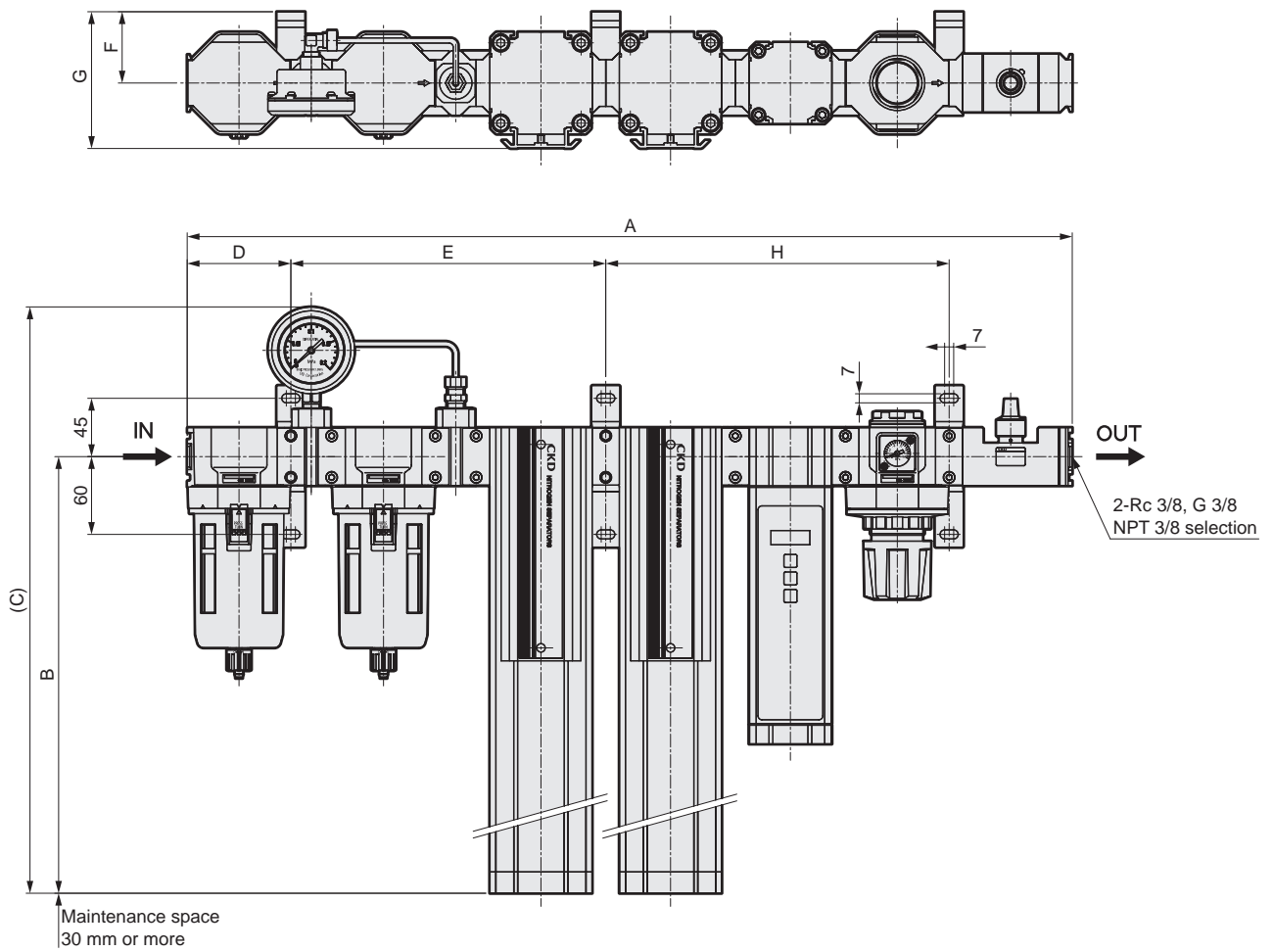

Model No.	A	B	C	D	E	F	G	H	Weight (kg)
NSU-4F*10*A*	683	543	658	80	243	55	106	265	12.5
NSU-4G*10*A*	683	1043	1158	80	243	55	106	265	15.3
NSU-4H*10*A*	683	1043	1158	80	243	55	106	265	18.1

## Dimensions (2-station type)

- No oxygen monitor, with flow rate sensor (NSU-4<sup>F</sup><sub>H</sub>\*10\*B\*)

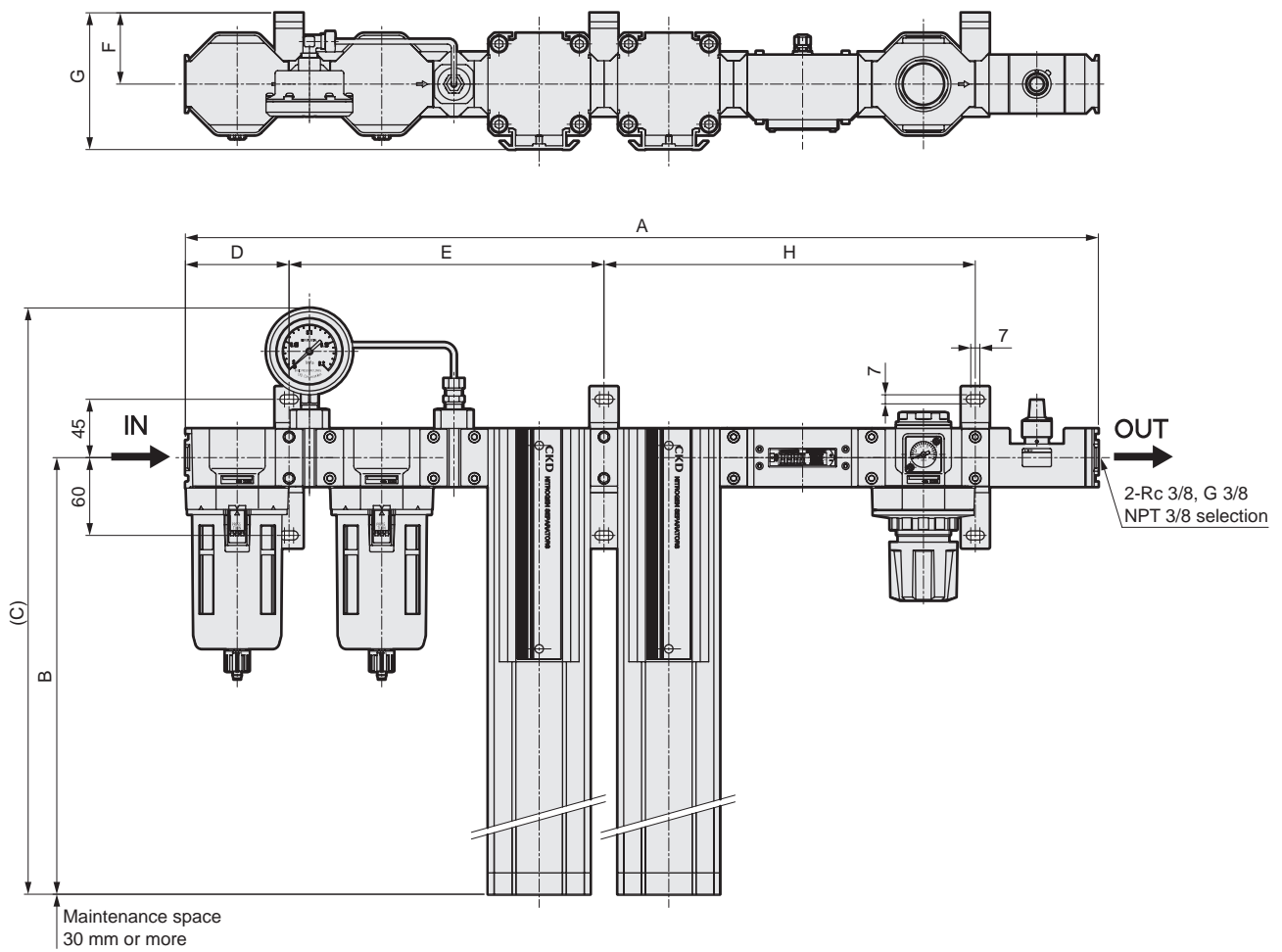

Model No.	A	B	C	D	E	F	G	H	Weight (kg)
NSU-4F*10*B*	704.5	543	658	80	243	55	106	286.5	11.7
NSU-4G*10*B*	704.5	1043	1158	80	243	55	106	286.5	14.5
NSU-4H*10*B*	704.5	1043	1158	80	243	55	106	286.5	17.3

## Dimensions (2-station type)

- With oxygen monitor and flow rate sensor (NSU-4<sup>F</sup><sub>H</sub>\*10\*C\*)

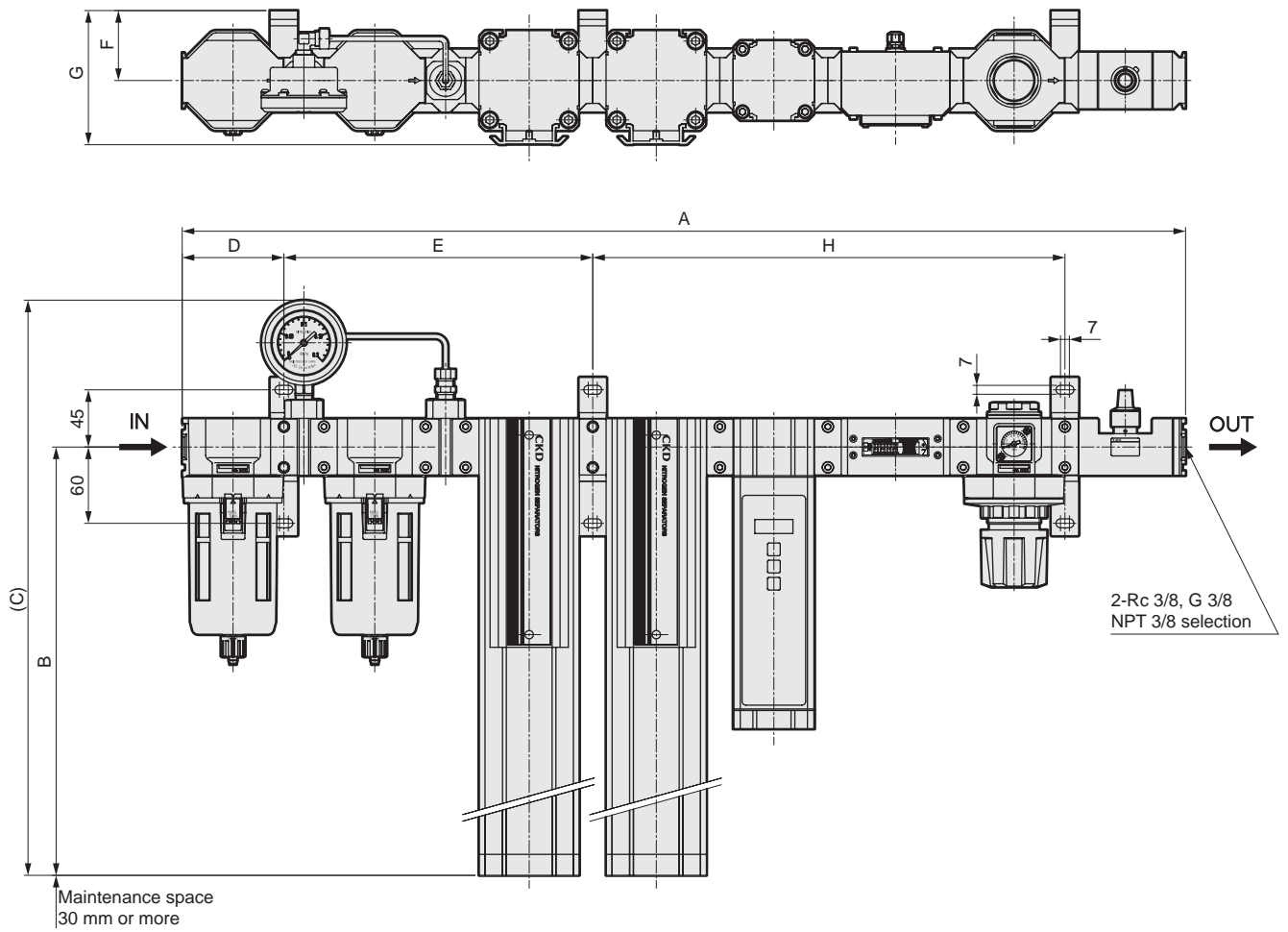

Model No.	A	B	C	D	E	F	G	H	Weight (kg)
NSU-4F*10*C*	789.5	543	658	80	243	55	106	371.5	13.3
NSU-4G*10*C*	789.5	1043	1158	80	243	55	106	371.5	16.1
NSU-4H*10*C*	789.5	1043	1158	80	243	55	106	371.5	18.9



Inline oxygen monitor

# PNA Series

Purging not required due to the inline pressure resistant structure  
A modular structure that can be connected to the Nitrogen Gas Extraction Unit NS Series and F.R unit



## Specifications

Item	Description
Measuring method	Zirconia solid electrolyte method
Sampling method	Natural diffusion
Display	Can be switched between oxygen concentration display and nitrogen concentration display (100 - oxygen concentration)
Working fluid	Nitrogen-rich compressed air
Working pressure MPa	0 to 1.0
Proof pressure MPa	1.5
Ambient temperature, humidity	0 to 50°C, 80% RH or less (no condensation)
Fluid temperature	0 to 50°C (no condensation)
Storage ambient temperature, humidity	-10 to 60°C, 80% RH or less (no condensation)
Max. flow rate L/min (ANR)	500 (*1)
Measured range % O <sub>2</sub>	0.00 to 25.00
Accuracy (*2)	±0.05% O <sub>2</sub> ±1digit (For 0.00 to 1.00% O <sub>2</sub> ) ±0.10% O <sub>2</sub> ±1digit (For 1.01 to 2.50% O <sub>2</sub> ) ±0.5% O <sub>2</sub> ±1digit (For 2.51 to 10.00% O <sub>2</sub> ) ±1.0% O <sub>2</sub> ±1digit (For 10.01 to 25.00% O <sub>2</sub> )
Response time	90% response within 20 seconds (*3)
Analog output	4 to 20 mA current output (for 0.00 to 25.00% O <sub>2</sub> )
Load resistance of analog output	0 to 400 Ω
Analog output accuracy	0.064 mA/0.1% O <sub>2</sub>
Switch output	Set value and detection element abnormality: 1 (relay output)
Switch output capacity	24 VDC, 1 A
Power supply voltage	24 VDC ± 15% (when AC adapter is used: 100 to 240 VAC)
Power consumption	10 W or less
Degree of protection	IP65 or equivalent
EMC Directive	EN61326-1
Weight kg	1.6
Warmup time	About 5 minutes after turning on the power supply (*4)

\*1 For values exceeding 500 L/min (ANR), consult with CKD.

\*2 Value in dry gas composed of oxygen and nitrogen.

\*3 Response times are values under a flow rate of 5 L/min (ANR) or higher.

\*4 Analog output and switch output are not output during warm up.

## How to order main body

PNA-10A-N-FP2

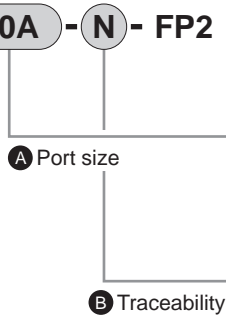

\* Connector cable is not included.  
Refer to page 16 for details.

Code	Description
<b>A Port size</b>	
10A	Rc3/8
10B	G3/8
10C	NPT3/8
<b>B Traceability</b>	
N	No
M	Traceability certification with series variation diagram and company certification

[Example of model No.]

**PNA-10A-M-FP2**

**A** Port size: Rc3/8

**B** Traceability: Traceability certification with series variation diagram and company certification

## Dimensions

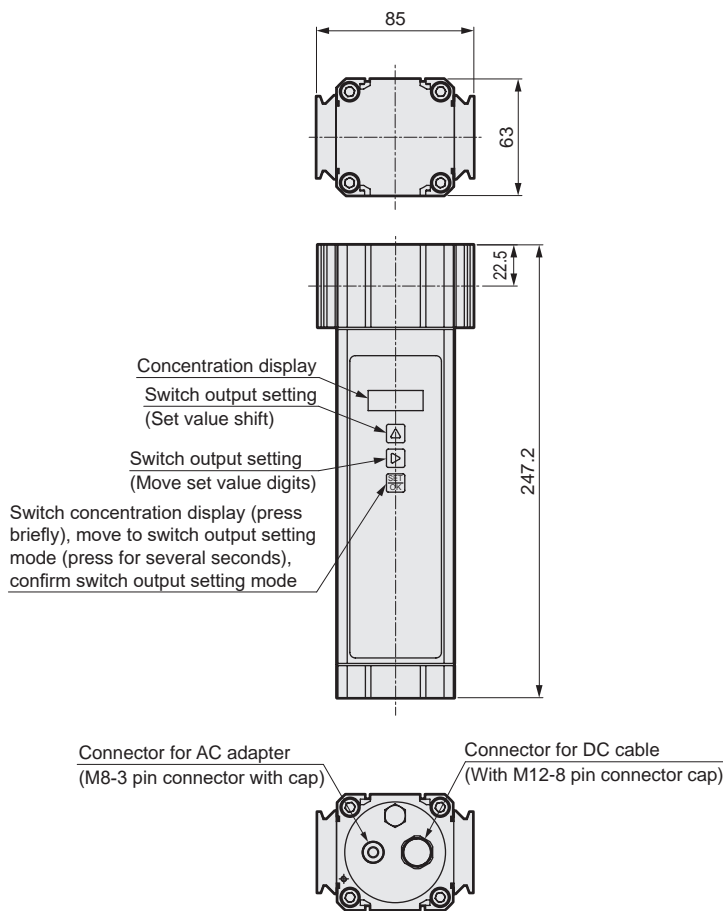

**Cannot be disassembled**

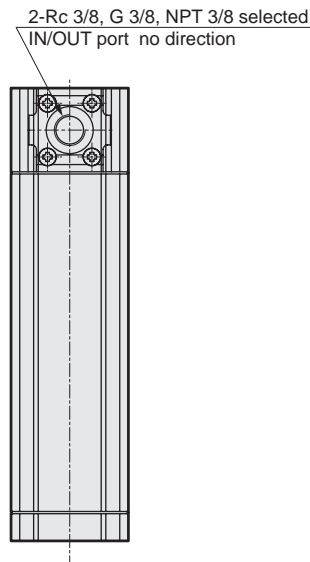

## How to order connector cable and dimensions

\*Connector cable is sold separately from the body.

### ● DC cable

Use when driving with a DC power supply and when using analog output or switch output.

Model No.	Dimension L	No.	Cable color	Description
PNA-1D	1000	1	White	Power supply +
PNA-3D	3000	2	Brown	Power supply -
PNA-5D	5000	3	Green	Analog output +
		4	Yellow	Analog output -
		5	Gray	Contact output
		6	Pink	(relay output)
		7	Blue	-
		8	-	-

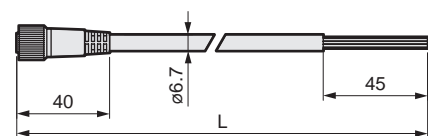

### ● AC adapter

Use when driving with an AC power supply.

Model No.	Description
PNA-A	AC adapter single unit A
PNA-AG	AC adapter + conversion plug set *Global power supply conversion plugs B, C, O and BF included.

#### • Plug shape

B type	C type	O type	BF type

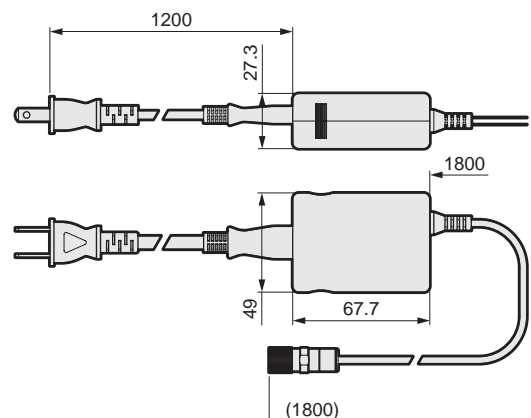



Flow rate sensor for nitrogen gas extraction unit

# NS-QFS Series

A modular structure that can be connected to the Nitrogen Extraction Unit NS Series

● Flow rate range: 20 L/min to 500 L/min



## NS-QFS specification

Item	NS-QFS-A	NS-QFS-B	NS-QFS-C	NS-QFS-D	NS-QFS-E
Flow direction	Uni-direction				
Measurement flow rate range *1 (L/min)	0.6 to 20	1.5 to 50	3 to 100	6 to 200	15 to 500
Display	4 digit +4 digit 2 color LCD				
Flow rate display range *2 (L/min)	-1.9 to 21.9	-4.9 to 54.9	-9.9 to 109.9	-19 to 219	-49 to 549
Integration display *3	Display range L	0.0 to ± 999999.9 L			0 to ± 9999999 L
	Pulse output rate L	0.2	0.5	1	2
Working conditions	Applicable fluids	Nitrogen gas			
	Temperature range °C	5 to 50 (no condensation)			
	Pressure range MPa	0 to 1.0			0 to 0.75
	Proof pressure MPa	1.5			
Operating ambient temperature/humidity	5 to 50 °C, 90% RH or less				
Storage temperature °C	-10 to 60				
Accuracy *4 (Fluid: in dry air)	Accuracy *5	Within ±3% F.S. (Secondary side released to atmosphere) (The scope of warranty is in accordance with the "measurement flow rate range.")			
	Repeatability *6	Within ±1% F.S. (Secondary side released to atmosphere)			
	Temperature characteristics	Within ±0.2% F.S./°C (15 to 35 °C, base temperature 25 °C)			
	Pressure characteristics	Within ±5% F.S. (0.35 MPa reference)			
Response time *7	50 msec or less (setting response time OFF)				
Switch output [B]	N	NPN open collector 1 point output (50 mA or less, voltage drop 2.4 V or less)			
	P	PNP open collector 1 point output (50 mA or less, voltage drop 2.4 V or less)			
Analog output	4 to 20 mA current output (connecting load impedance 0 to 300 Ω)				
Power supply voltage	24 VDC (21.6 to 26.4 V) ripple rate 1% or less				
Current consumption *8	45 mA or less				
Lead wire	ø3.7, AWG26 or equivalent x 5-conductor, insulator O.D. ø1.0, length 2.5 m				
Functions	(1) setting copy function, (2) flow rate integration, (3) peak hold, etc.				
Degree of protection	IP40 or equivalent (IEC standard)				
Protection circuit *9	Power reverse connection protection, switch output reverse connection protection, switch output load short-circuit protection				
EMC Directive	EN55011, EN61000-6-2, EN61000-4-2/3/4/6/8				
Weight kg	0.8				

\*1: The value converted to volumetric flow rate at standard condition (20 °C 1 barometric pressure (101 kPa) relative humidity 65%).

\*2: Display at each flow rate is as follows.

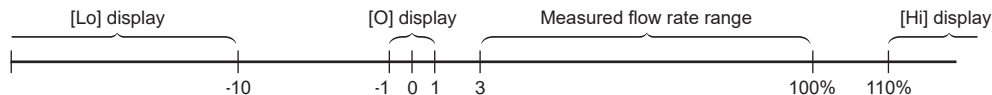

\*3: The accumulated flow is a calculated (reference) value. When using the integrated save function, take care to prevent the number of saves from exceeding the access count limit of the storage device (1 million times). (Changes to various settings also are counted in the access count.)

Number of saves = Usage time / 5 minutes < 1 million times

When instantaneous flow rate is below 1% it is not counted as integrating flow.

\*4: Compressed air is used for adjusting and inspecting this product.

\*5: Accuracy is based on a CKD standard flow rate meter. It does not indicate absolute accuracy. Repeatability, temperature characteristics, and pressure characteristics are not included for an accuracy of ± 3% F.S.

\*6: Repeatability calculated during a short time. Change over time is not included.

\*7: The actual response time changes depending on the piping conditions. As a guideline, the response time can be set within the range of 50 msec to 1.5 sec.

\*8: Current for when no load is applied. Please note that the current consumption changes depending on the load connection status.

\*9: This product's protection function is effective only for specific misconnections and load short-circuits. It does not provide protection for all misconnections.

## How to order

NS-QFS - **A** **N** **1**

**A** Flow rate range (full scale flow rate)

**B** Switch output

**C** Unit specifications

Code	Description
<b>A Flow rate range (full scale flow rate)</b>	
A	Flow rate range 20 L/min
B	Flow rate range 50 L/min
C	Flow rate range 100 L/min
D	Flow rate range 200 L/min
E	Flow rate range 500 L/min
<b>B Switch output</b>	
N	NPN transistor open collector output 1 point
P	PNP transistor open collector output 1 point
<b>C Unit specifications</b>	
1	SI units only
2	With unit switching function (overseas models only) *1

## ⚠ Precautions for model No. selection

\*1: Models with the unit switching function are not sold in Japan.

\*2: When using the NSU series reverse flow option, invert the display. Refer to page 22 for display inversion settings.

\*3: The joiner set (joiner, bolt, O-ring) and one gasket are included.

## Dimensions

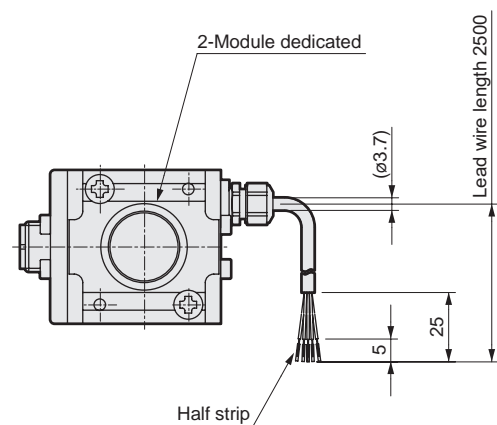
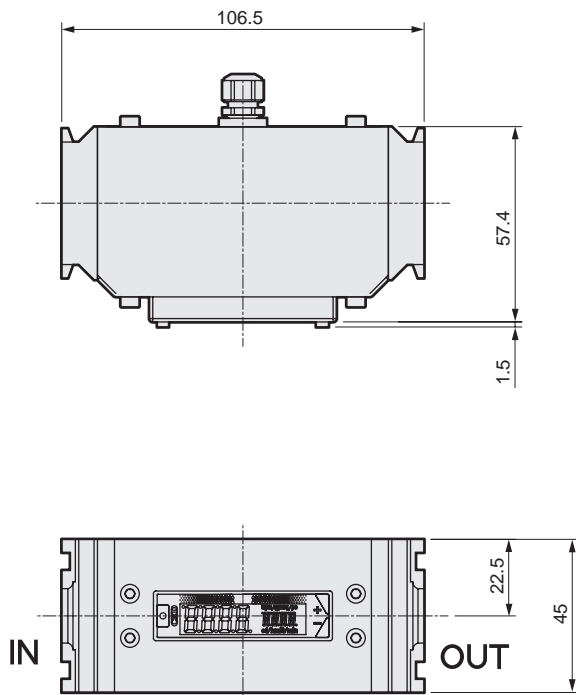

## Example of internal circuit and load connection

### ● NPN output

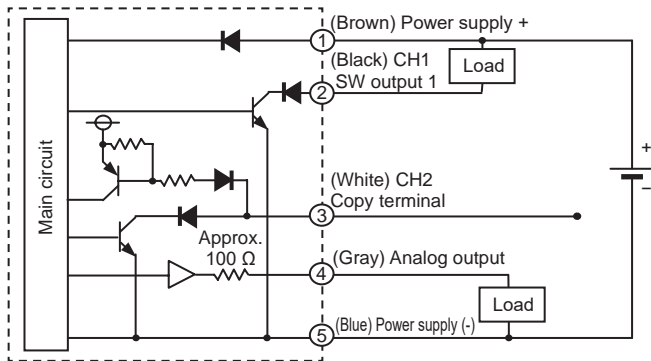

### ● PNP output

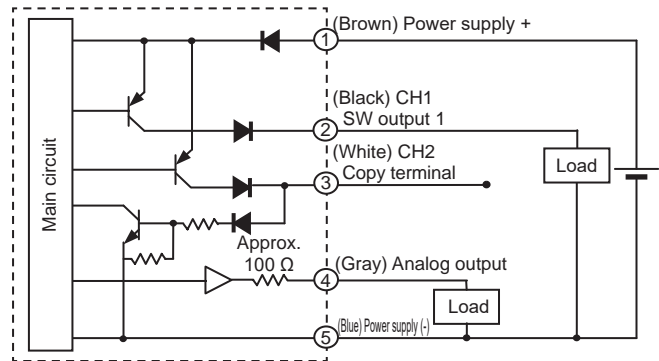

Terminal No.	Option Lead wire color	Name
(1)	Brown	Power supply (+) (voltage output: 12 to 24 V, current output: 24 V)
(2)	Black	CH1 (Switch output 1: max. 50 mA)
(3)	White	CH2 (copy terminal)
(4)	Gray	Analog output Current output: 4 to 20 mA load impedance 300 Ω or less
(5)	Blue	Power supply - (GND)

<When using setting copy function>

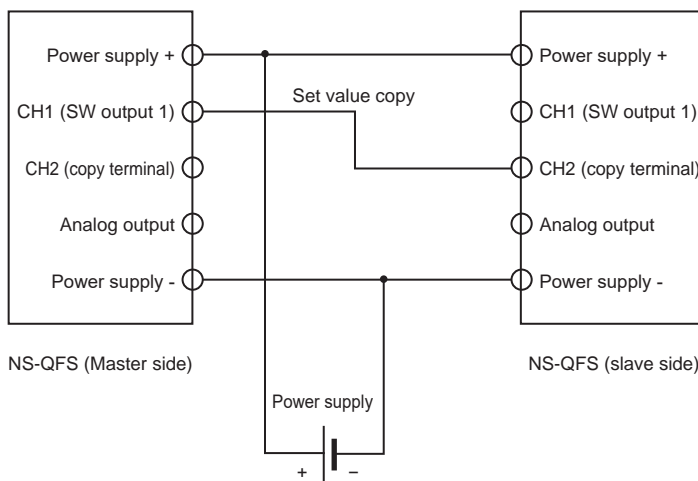

Connect CH1 (SW output 1) on the master side to CH2 (copy terminal) on the slave side and power ON the sensor to use the setting copy function (F93). Use this connection only when using the setting copy function.  
As with the load connection example above, if copying is performed with the load connected to CH1, or the switch is operated while CH1 and CH2 are connected the device may operate unexpectedly or the device and NS-QFS may malfunction. Never use the unit with the copy terminal connected.

Analog output characteristics

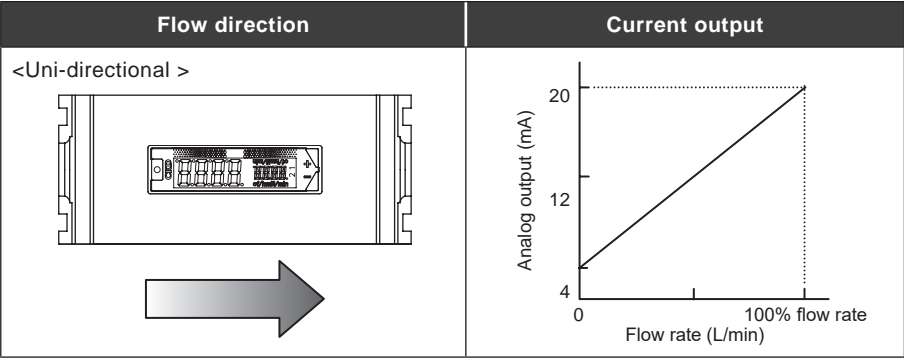

## Names and functions of display/operation section (LCD display)

### ● Display section name

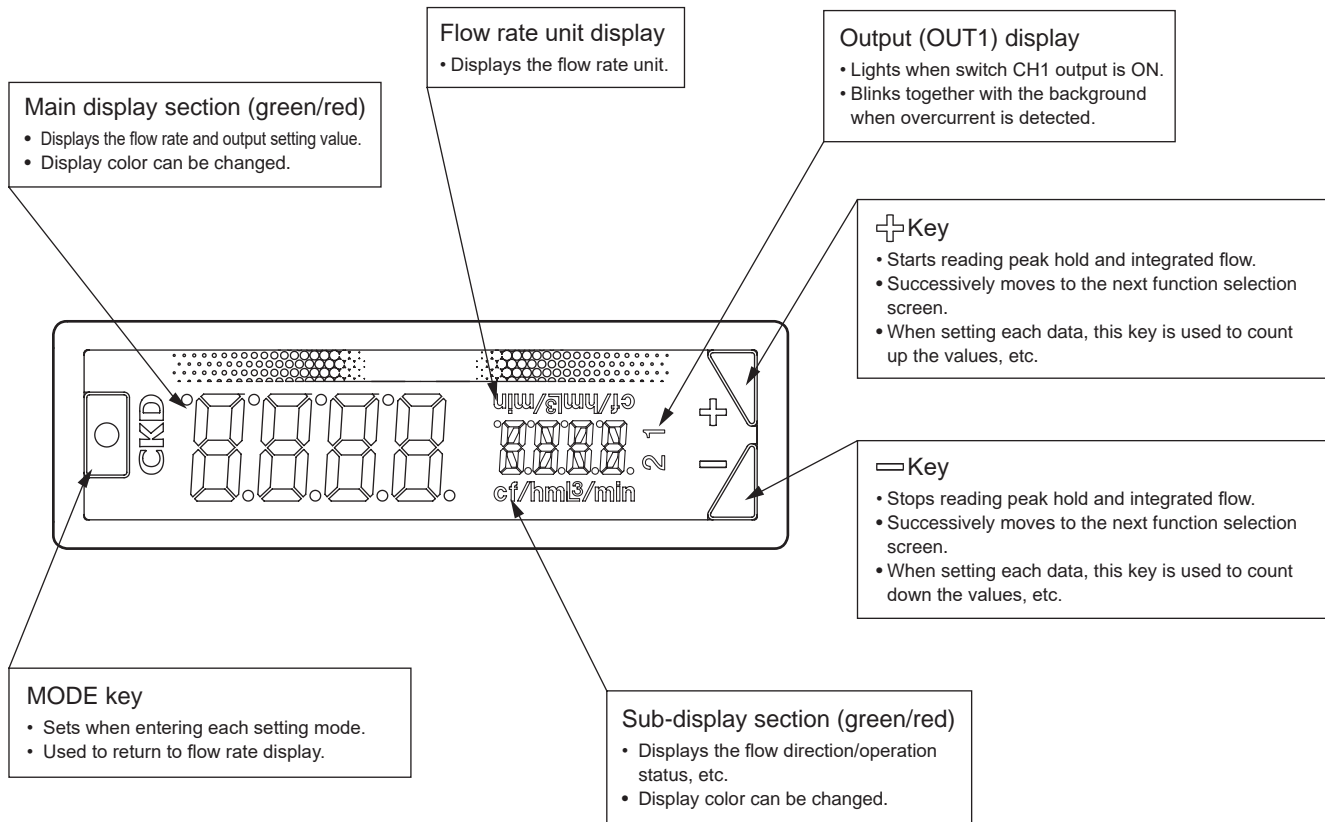

### Names and functions of display/operation section

The function and various settings may be performed during normal flow rate display or after entering each mode.  
The modes are also divided into Maintenance mode, SET mode, and Setting Monitor mode according to the frequency of use.

#### ● Normal operation (RUN mode)

Item	Explanation	Default setting
Instantaneous flow rate display	Displays the instantaneous flow rate.	Display (measurement)
Peak hold function	Max. and min. values for the flow rate within a set interval are displayed.	Non-display (stop)
Accumulated flow display	The accumulated flow can be displayed. The switch output function includes a function to turn the switch ON/OFF at a level higher than the recommended cumulative value, and an integrated pulse function to output the pulse at a set cumulative value.	Non-display (measurement)

#### ● SET mode

No.	Item	Explanation	Default setting
F.01	Selection of CH1 operation	Select the CH1 setting. Switch output operation and integrated pulse settings can be set.	No switch output
F.03	Integrating function settings	You can choose to acquire integrating flow values consecutively or at set times. You can also choose to keep the data or not.	Continuous acquisition: Data hold OFF
F.04	Sub-screen display setting	Set the sub-display section's display method. Can be switched to flow direction, reference state, or numbering display.	Flow direction
F.05	Display color setting	Set the display color. (red, green) The color for a normal display and for switch output ON can be set.	At normal: Green At switch ON: Red
F.07	Display inversion function	The LCD display can be vertically inverted.	Standard display
F.08	Reference state setting	Select from the standard state or reference state. Standard state (ANR): Converted into volumetric flow rate at 20 °C, 1 barometric pressure, relative 65% Reference state (NOR): Converted into volumetric flow rate at 0°C, 1 barometric pressure, 0% RH	ANR
F.09	Unit setting (For overseas only)	The units can be set. Can be selected from L/min and cf/h.	Domestic model: L/min Overseas model: L/min
F.10	Display cycle setting	The digital display refresh cycle can be set in three stages from 0.25 s to 1 s. If the display flickers, it may be improved by setting a longer display refresh cycle.	0.5sec
F.11	Analog output Setting response time	Set the response time. response can be set in seven stages from 0.05 s to approx. 1.50 s. Chattering and mis-operation caused by sudden flow rate changes or noise are prevented.	0.05sec
F.12	Numbering setting	You can set the numbering.	0000
F.14	Setting ECO mode	An ECO mode can be set. If the buttons are not operated for approx. one minute, the eco mode will activate and turn off the display's backlight. Current consumption can be reduced with this mode.	OFF
F.16	Lock setting	You can set the key lock method and the PIN code method. Use selectively depending on the working environment.	OFF
F.17	Peak hold setting	You can choose to acquire peak bottom values consecutively or at set times. You can also choose to keep the data or not.	Continuous acquisition: Data hold OFF

#### ● Maintenance mode

No.	Item	Explanation	Default setting
F.91	Forced output function	Use this function to forcibly turn the switch output ON and confirm the wiring connection or initial operation of the input device.	-
F.92	Zero adjustment	The zero point deviation is compensated.	Adjust value: 0
F.93	Setting copy function	Set values can be copied if the model supports copying between two NS-QFS's. (Copying is only possible between products with the same model No.)	-
F.99	Reset function	Returns the settings to the default settings.	-

#### ● Setting monitor mode

Item	Explanation	Default setting
Settings monitor function	Details set in the SETmode can be confirmed. (Setting details cannot be edited.)	-

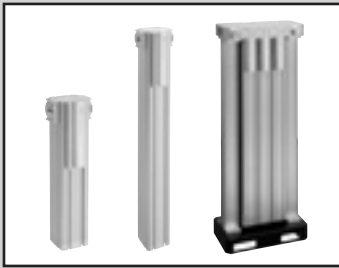

Nitrogen gas extraction unit

# NS Series

Modular design for easy system expansion with peripheral components

■ Nitrogen gas is obtained just by supplying compressed air.



## Specifications

■ Single cylinder

Item		NS-3S1	NS-3L1	NS-4S1	NS-4L1		
Range of working conditions	Working fluid	Compressed air					
	Inlet air pressure MPa	0.4 to 1.0					
	Proof pressure MPa	1.5					
	Inlet air temperature °C	5 to 50					
	Relative humidity of inlet air RH	50% or less					
	Ambient temperature °C	5 to 50					
Rating	Inlet air purity class	1:6:1(JIS B 8392-1:2012, ISO 8573-1:2010)					
	Inlet air pressure MPa	0.7					
	Inlet air temperature °C	25					
	Ambient temperature °C	25					
Rated flow rate	Outlet nitrogen gas flow rate L/min(ANR)	Nitrogen concentration (%) or higher	99.9	1.9	5.6	11.0	30.6
			99	5.0	15.5	28.2	66.9
			97	8.9	28.7	49.9	118.1
			95	14.0	39.8	65.3	169.2
			90	27.0	78.1	137.3	313.5
	Inlet air flow rate L/min(ANR)	Nitrogen concentration (%) or higher	99.9	17.3	50.9	100.0	278.2
			99	20.9	64.6	117.5	278.8
			97	24.1	77.6	134.9	319.2
			95	31.2	88.5	145.2	376.0
			90	60.0	173.6	305.1	696.7

■ Double cylinder

Item		NS-4S2	NS-4S3	NS-4L2	NS-4L3	NS-4L4	NS-4S6	NS-4S8	NS-4SA	NS-4L6	NS-4L8		
Range of working conditions	Working fluid	Compressed air											
	Inlet air pressure MPa	0.4 to 1.0											
	Proof pressure MPa	1.5											
	Inlet air temperature °C	5 to 50											
	Relative humidity of inlet air RH	50% or less											
	Ambient temperature °C	5 to 50											
Rating	Inlet air purity class	1:6:1 (JIS B 8392-1:2012, ISO 8573-1:2010)											
	Inlet air pressure MPa	0.7											
	Inlet air temperature °C	25											
	Ambient temperature °C	25											
RatingFlow rate	Outlet nitrogen gas flow rate L/min(ANR)	Nitrogen concentration (%) or higher	99.9	22.0	33.0	61.2	91.8	122.4	66.0	88.0	110.0	183.6	244.8
			99	56.4	84.6	133.8	200.7	267.6	169.2	225.6	282.0	401.4	535.2
			97	99.8	149.7	236.2	354.3	472.4	299.4	399.2	499.0	708.6	944.8
			95	130.6	195.9	338.4	507.6	676.8	391.8	522.4	653.0	1015.2	1353.6
			90	274.6	411.9	627.0	940.5	1254.0	823.8	1098.4	1373.0	1881.0	2508.0
	Inlet air flow rate L/min(ANR)	Nitrogen concentration (%) or higher	99.9	200.0	300.0	556.4	834.6	1112.8	600.0	800.0	1000.0	1669.2	2225.6
			99	235.0	352.5	557.6	836.4	1115.2	705.0	940.0	1175.0	1672.8	2230.4
			97	269.8	404.7	638.4	957.6	1276.8	809.4	1079.2	1349.0	1915.2	2553.6
			95	290.4	435.6	752.0	1128.0	1504.0	871.2	1161.6	1452.0	2256.0	3008.0
			90	610.2	915.3	1393.4	2090.1	2786.8	1830.6	2440.8	3051.0	4180.2	5573.6

Note: The product will be floor-mounted for 6 units or more.

## Selection guide

The temperature and inlet air pressure affect the outlet nitrogen gas flow and should be corrected if they differ from the ratings in the specification section.

**STEP 1** Confirm the working conditions and specification rates.

Working conditions: Inlet air pressure, inlet air temperature, required nitrogen gas flow rate

**STEP 2** Confirm the compensation coefficient of outlet nitrogen gas flow rate affected by inlet air temperature.

(1) Temperature - Gas flow rate compensation coefficient

Temperature (°C)	Outlet nitrogen gas concentration				
	99.9%	99%	97%	95%	90%
5	0.64	0.79	0.79	0.75	0.78
10	0.73	0.84	0.84	0.81	0.84
25	1	1	1	1	1
35	0.97	1.05	1.04	1.07	1.07
40	0.95	1.08	1.06	1.11	1.11
50	0.9	1.09	1.11	1.15	1.2

**STEP 3** Confirm the compensation coefficient of outlet nitrogen gas flow rate affected by inlet air pressure.

(2) Pressure - Gas flow rate compensation coefficient

Pressure (MPa)						
0.4	0.5	0.6	0.7	0.8	0.9	1.0
0.4	0.65	0.75	1	1.07	1.2	1.3

**STEP 4** Determine the appropriate model from the rated outlet nitrogen gas flow rate of each model.

Rated outlet nitrogen gas flow rate x (1) temperature gas flow rate correction coefficient x (2) pressure gas flow rate correction coefficient = corrected outlet nitrogen gas flow rate

Select one with sufficient outlet nitrogen gas flow rate after correction with the above formula.

**STEP 5** Confirm the compensation coefficient of inlet air flow rate affected by inlet air temperature.

(3) Temperature - Air flow rate compensation coefficient

Temperature (°C)	Outlet nitrogen gas concentration				
	99.9%	99%	97%	95%	90%
5	0.73	0.68	0.75	0.69	0.76
10	0.8	0.76	0.81	0.77	0.82
25	1	1	1	1	1
35	1.21	1.17	1.11	1.13	1.11
40	1.32	1.25	1.17	1.2	1.16
50	2.05	1.38	1.31	1.31	1.3

**STEP 6** Confirm the compensation coefficient of inlet air flow rate affected by inlet air pressure.

(4) Pressure - Air flow rate compensation coefficient

Pressure (MPa)						
0.4	0.5	0.6	0.7	0.8	0.9	1.0
0.61	0.79	0.91	1	1.07	1.2	1.3

**STEP 7** Determine the inlet air flow rate from the rated outlet nitrogen gas flow rate of each model.

Inlet air flow rate of the model selected in STEP 4 x (3) temperature air flow rate correction coefficient x (4) pressure air flow rate correction coefficient = corrected inlet air flow rate  $\ell/\text{min}$  (ANR)

Based on the inlet air flow rate corrected as above, confirm whether the compressor capacity is sufficient.

Example of calculation

Conditions	Working conditions	Selecting conditions	Compensation coefficient for outlet nitrogen gas flow rate	Compensation coefficient for inlet air flow rate
Inlet air temperature	35 to 39°C	35°C	(1) 1.05	(3) 1.17
Inlet air pressure	0.5 to 0.55 MPa	0.5 MPa	(2) 0.65	(4) 0.79

Substitute the above conditions into the equation above to obtain the outlet nitrogen gas flow rate when using NS-4L1 at a nitrogen concentration of 99%.  
 $66.9$  (rated outlet nitrogen gas flow rate)  $\times 1.05 \times 0.65 = 45.7 \text{ L/min}$  (ANR)

If the required nitrogen gas flow rate is less than or equal to this value, select that model.

In this case, the inlet air flow rate is  $278.8 \times 1.17 \times 0.79 = 257.7 \text{ L/min}$  (ANR)

## How to order

NS - 4 S 1 10A - B T - FP2

Model No.

A Body size

B Membrane unit size

C Quantity

D Port size

E Option

F Mounting direction

G Series

Code	Description
<b>A Body size</b>	
3	Body width 63
4	Body width 79
<b>B Membrane unit size</b>	
S	Short
L	Long
<b>C Quantity</b> (*1)	
1	1 pc.
2	2 pcs. (Select from models NS-4S, and 4L)
3	3 pcs. (Select from models NS-4S, and 4L)
4	4 pcs. (Selectable model is NS-4L)
6	6 pcs. (Select from models NS-4S, and 4L)
8	8 pcs. (Select from models NS-4S, and 4L)
A	10 pcs. (Selectable model is NS-4S)
<b>D Port size</b>	
10A	Rc 3/8(NS-3S1,3L1,4S1,4L1)
10B	G 3/8(NS-3S1,3L1,4S1,4L1)
10C	NPT 3/8(NS-3S1,3L1,4S1,4L1)
20A	Rc 3/4(NS-4S2,4S3,4L2,4L3,4L4)
20B	G 3/4(NS-4S2,4S3,4L2,4L3,4L4)
20C	NPT 3/4(NS-4S2,4S3,4L2,4L3,4L4)
25A	Rc 1(NS-4S6,4S8,4SA,4L6,4L8)
25B	G 1(NS-4S6,4S8,4SA,4L6,4L8)
25C	NPT 1(NS-4S6,4S8,4SA,4L6,4L8)
<b>E Option</b> (*2)	
N	No option
B	Bracket
C	Bracket + reverse flow (*3)
D	Bracket + exhaust port
F	Bracket + reverse flow + exhaust port (*3)
X	Reverse flow (*3)
E	With exhaust port
H	Reverse flow + With exhaust port (*3)
<b>F Mounting direction</b>	
Blank	Vertical mounting
T	Horizontal mounting (available with NS-4S1, 4L1)
<b>G Series</b>	
Blank	Standard
FP2	Series for food processing

### ⚠ Precautions for model No. selection

- \*1: The product will be floor-mounted without bracket for 6 units or more.
- \*2: Exhaust air (oxygen-enriched gas) from standard products is released into the atmosphere. Specify "D", "F", "E" and "H" to enable piping connection for exhaust air (oxygen-enriched gas). Size of exhaust port is Rc1/2.
- \*3: Viewed from the front, a standard product has an air inlet on the left port, while an air outlet on the right port. For "C", "F", "X" and "H", an air inlet is provided on the right port, with an air outlet provided on the left port.

## Dimensions

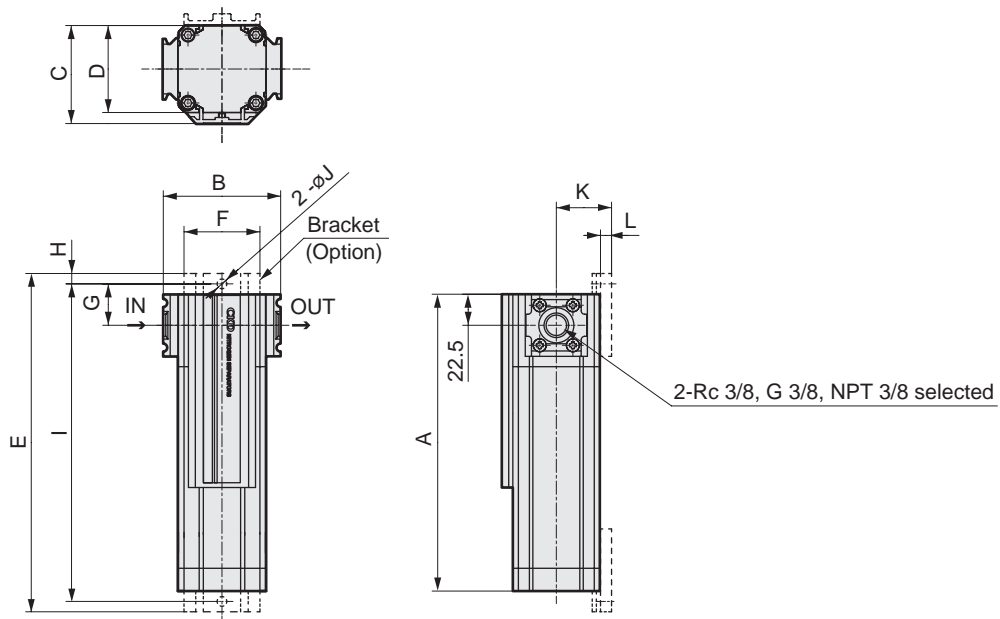

Model No.	A	B	C	D	Weight (kg)	Bracket relational dimensions							
						E	F	G	H	I	J	K	L
NS-3S1	315	85	71	63	1.8	345	55	30	7.5	330	7	40	8
NS-3L1	565	85	71	63	2.7	595	55	30	7.5	580	7	40	8
NS-4S1	565	100	90	79	4.0	605	70	32.5	10	585	9	50	10
NS-4L1	1065	100	90	79	6.8	1105	70	32.5	10	1085	9	50	10

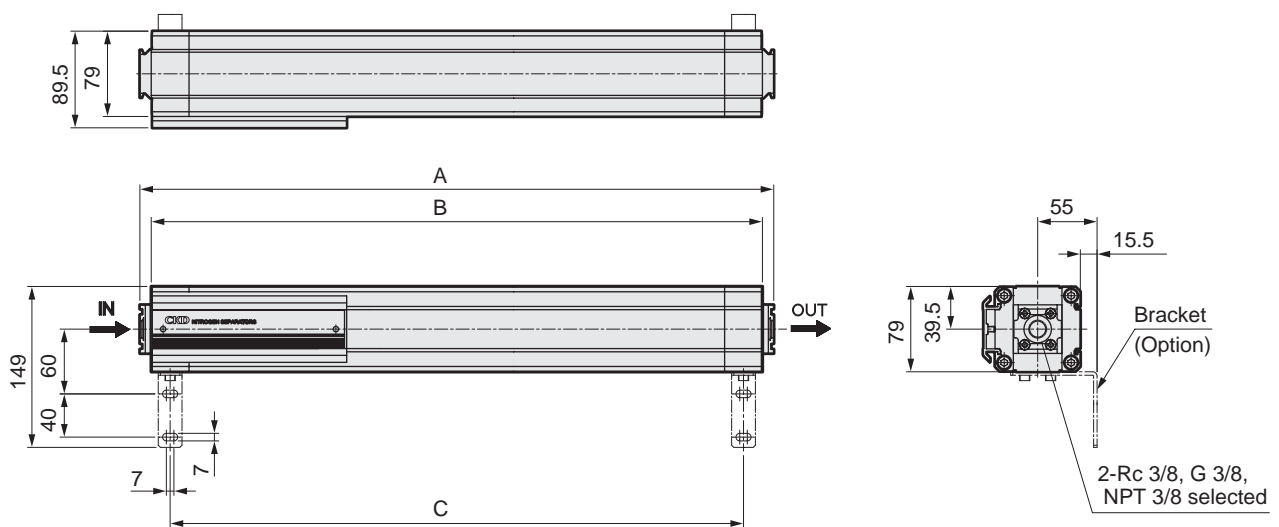

Model No.	A	B	C	Weight (kg)
NS-4S1*-*T	587	566	531	4.2
NS-4L1*-*T	1087	1066	1031	7.0

## Dimensions

● Qty: 2, 3, 4 units

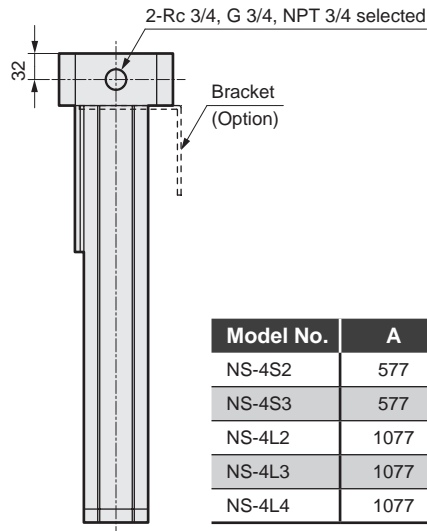
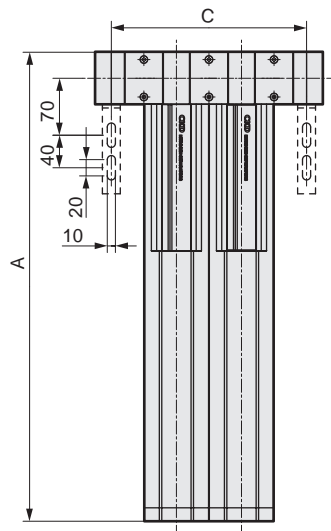
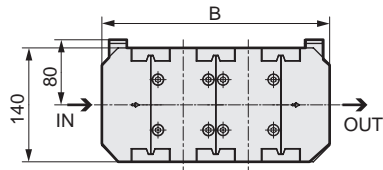

Model No.	A	B	C	Weight (kg)
NS-4S2	577	280	240	12
NS-4S3	577	360	320	17
NS-4L2	1077	280	240	18
NS-4L3	1077	360	320	25
NS-4L4	1077	440	400	32

● Qty: 6, 8 or 10 units

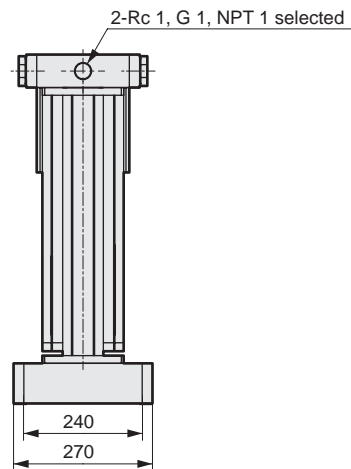
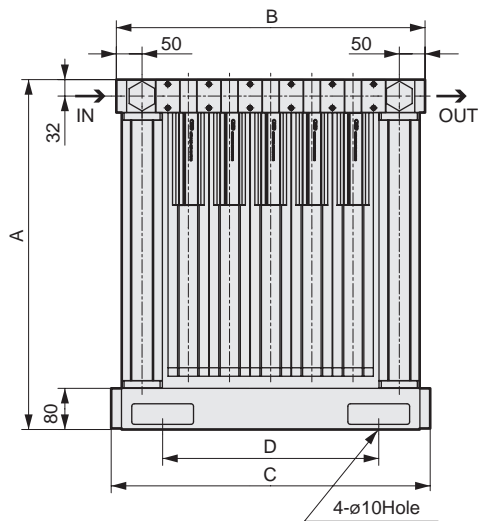
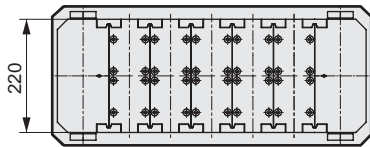

Model No.	A	B	C	D	Weight (kg)
NS-4S6	680	440	460	260	41
NS-4S8	680	520	540	340	50
NS-4SA	680	600	620	420	59
NS-4L6	1180	440	460	260	63
NS-4L8	1180	520	540	340	78