

### ISO15552 Standard Cylinder SCW \* 2 Series



#### ISO15552 STANDARD SCW \* 2 SERIES

ISO Series Cylinder Released on the Market

*New*



# Comply with ISO15552 Standard New Cylinder

User friendly design, safety and convenience greatly improved, and SCW \* 2 (φ32 ~ φ100) new cylinder focusing on matching the modern design of new machine.

## Light weight

Mass reduced by 20% compared with the last generation of products

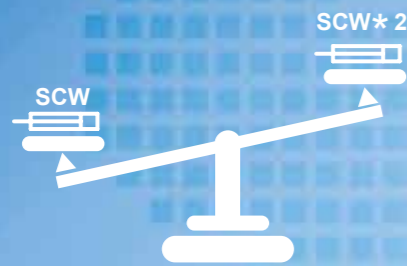

## Small switches directly installed

(Only limited to SCWP2)  
Safe, reliable and adjustable



## New tie rod installation switch

(Only limited to SCWT \* 2 series)  
Bracket is installed on the pull rod  
Carrying small switches



Standard  
SCWP2



Tie rod model  
SCWT2

## White series

To match relevant components, front and rear cover designed in white.



## Air orifice and cushion regulate needle valve on the same plane

Exhausting orifice and cushion regulate needle valve on the same plane, and cylinder is easily installed and adjusted.



## Cushion valve easily adjusted

Adjustable with slot type screwdriver. Needle valve buried into cylinder cover, superior safety.



## Switch installation channel on four sides of the cylinder

Greater room for selection of switch installation to satisfy customers requirements.

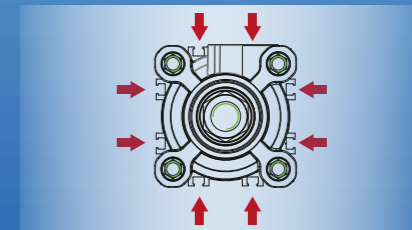



● :Standard, ○ : Option

				Mounting Style									Cushion	Options	Accessories					Switch
				Basic	Axial Foot	Rod Side Flange	Head Side Flange	Eye Bracket	Clevis Bracket	Center Trunnion	Rod Side Trunnion	Head Side Trunnion	Both sides Cushion	Piston rod material change(Stainless steel)	Rod Eye	Rod Clevis	Eye Bracket	Clevis Bracket	Eye Bracket	
600	700	800	00	LB	FA	FB	CA CA2	CB CB2	TC TC2	TA TA2	TB TB2	B	M	I	Y Y2	B1 B5	B2 B6	B3 B7		
			●	●	●	●	●	●				●	○	○	○	○	○	○	○	
●			●	●	●	●	●	●				●	○	○	○	○	○	○	○	
●	●	●	●	●	●	●	●	●				●	○	○	○	○	○	○	○	
			●	●	●	●	●	●	●	●	●	●	○	○	○	○	○	○	○	
●			●	●	●	●	●	●	●	●	●	●	○	○	○	○	○	○	○	
●	●	●	●	●	●	●	●	●	●	●	●	●	○	○	○	○	○	○	○	



# ISO1552 standard cylinder

## SCW \* 2 Series

● Bore Size:  $\phi 32 \cdot \phi 40 \cdot \phi 50 \cdot \phi 63 \cdot \phi 80 \cdot \phi 100$

ISO symbol

### Specifications

Description		SCW * 2					
Bore size	mm	$\phi 32$	$\phi 40$	$\phi 50$	$\phi 63$	$\phi 80$	$\phi 100$
Working fluid		Clean compressed air					
Max working pressure	MPa	1					
Min working pressure	MPa	0.05					
Withstanding pressure	MPa	1.5					
Ambient temperature	°C	-10~60 (No freezing)					
Stroke tolerance	mm	0~1.4					
Working piston speed	mm/s	50~1000					
Cushion		Air cushion					
Effective cushion length	mm	15	15	16.4	16.4	23.4	23.4
Lubrication		No (use turbine oil 1 type ISO VG32)					
Allowable absorption energy with cushion	J	2.5	6.0	9.0	14.4	25.4	45.6

### Stroke length

Bore size (mm)	Standard stroke length (mm)	Max. stroke length (mm)	Min. stroke length (mm)
$\phi 32$	25,50,80,100,125,160, 200,250,320,400,500, 600,700,800	500	1
$\phi 40$		500	
$\phi 50$		600	
$\phi 63$		600	
$\phi 80$		800	
$\phi 100$		800	

Notes: further negotiation is required beyond the max stroke length.

### Min stroke length of types with switch

Bore size (mm)	Switch quantity		1		2		3		4	
	proximity	reed	proximity	reed	proximity	reed	proximity	reed	proximity	reed
$\phi 32$	10		25		30		35			
$\phi 40$										
$\phi 50$										
$\phi 63$										
$\phi 80$										
$\phi 100$										

### Repair parts list

No.	Bore size	Kit number
1	$\phi 32$	SCWP2-32K
2	$\phi 40$	SCWP2-40K
3	$\phi 50$	SCWP2-50K
4	$\phi 63$	SCWP2-63K
5	$\phi 80$	SCWP2-80K
6	$\phi 100$	SCWP2-100K

Notes: general for SCWP2、SCWT2

### Cylinder mass

Bore size (mm)	Product mass when stroke length(s) = 0(mm)						Additional mass per S=50mm	Mass per TOH switch	Mass of switch mounting parts (T-shaped)	Accessory mass (Unit: kg)	
	Basic (00)	Foot (LB)	Flange (FA,FB)	Eye bracket (CA)	Clevis bracket (CB)	Trunnion (TA, TB, TC)				I	Y
SCWP2- $\phi 32$	0.48	0.59	0.70	0.63	0.66		0.16	0.018		0.07	0.10
SCWP2- $\phi 40$	0.68	0.82	0.96	0.87	0.87		0.20			0.07	0.13
SCWP2- $\phi 50$	1.12	1.28	1.60	1.53	1.53		0.29			0.20	0.30
SCWP2- $\phi 63$	1.50	1.84	2.26	2.06	2.07		0.30			0.20	0.30
SCWP2- $\phi 80$	2.33	2.76	3.90	3.60	3.61		0.55			0.52	0.94
SCWP2- $\phi 100$	3.44	4.30	5.76	5.16	5.19		0.55			0.48	0.92
SCWT2- $\phi 32$	0.45	0.56	0.67	0.60	0.63	0.62	0.09		0.024	0.07	0.10
SCWT2- $\phi 40$	0.63	0.77	0.91	0.82	0.82	0.97	0.13		0.024	0.07	0.13
SCWT2- $\phi 50$	1.03	1.19	1.51	1.44	1.44	1.51	0.18		0.022	0.20	0.30
SCWT2- $\phi 63$	1.37	1.71	2.13	1.93	1.94	2.25	0.20		0.020	0.20	0.30
SCWT2- $\phi 80$	2.02	2.45	3.59	3.29	3.30	3.51	0.39	0.026	0.52	0.94	
SCWT2- $\phi 100$	3.12	3.98	5.44	4.84	4.87	5.69	0.36	0.024	0.48	0.92	

### Switch specifications

- Monochrome/two-color show/anti-intense magnetic field

Description	Proximity 2 wire				Proximity 3wire			
	T1H · T1V	T2H · T2V · T2JH · T2JV	T2YH · T2YV	T2WH · T2WV	T3H · T3V	T3PH · T3PV	T3YH · T3YV	T3WH · T3WV
Applications	Programable controller, relay, small solenoid valve	Programable Controller			Programable controller, relay			
Output mode	-				NPN output	PNP output	NPN output	NPN output
Power voltage	-				DC10~28V			
Load voltage	AC85 to 265V	DC10 to 30V		DC24V±%01	DC30V or less			
Loading current	5~100 mA	5~20mA (Note 1)			100mA or less		50mA or less	
Load current light	LED (ON lighting)	LED (ON lighting)	Red/Green LED (ON lighting)	Red/Green LED (ON lighting)	LED (ON lighting)	Green LED (ON lighting)	Red/Green LED (ON lighting)	Red/Green LED (ON lighting)
Leaking current	AC100 V, 1mA or less AC200 V, 2mA or less	1mA or less			10µA or less			

Description	Reed 2-wire							Proximity 2-wire
	T0H · T0V	T5H · V5T		T8H8 · VT			T2YD	
Application	Programable controller, relay	Programable controller, relay IC loop (no indicator light)		Programable controller, relay			Programable Controller	
Output mode	-							
Power voltage	-							
Load voltage	DC12/24V	AC110V	DC5/12/24V	AC110V	DC12/24V	AC110V	AC220V	DC24V±10%
Load current	5~50mA	7~20mA	50mA or less	20mA or less	5~50mA	7~20mA	7~10mA	5~20mA
Light	LED (ON lighting)		No indicator light (ON lighting)		LED (ON lighting)			Red/Green LED (ON lighting)
Leaking current	0 mA							1mA or less

Note1: Max. load current : 20mA is the value at 25°C. When ambient temperature around a switch is higher than 25°C, the value is lower than 20mA (5 to 10mA at of 60°C).

### How to order

#### T-shaped switch

- Switch body + mounting component

**SCWT2 - T0H - 40**

Switch model No. Bore size  
(Only (F) of pages 3 and 4)

Notes: select the model when switch is mounted on the cylinder slot.

- Only switch body

**SW - T0H**

Switch model No.  
(Only (F) of pages 3 and 4)

- mounting component

**SCWT2 - TS - 40**

Mounting style Bore size

Notes: select the model when the mounting parts are to be repaired.

#### T2YD-shaped switch

- Switch body + mounting component

**SCWT2 - T2YD - 40**

Switch model bore size  
(Only (F) of pages 3 and 4)

Notes: select the model when switch is mounted on the cylinder slot.

- Only switch body

**SW - T2YD**

Switch model  
(Only (F) of pages 3 and 4)

- mounting component

**SCWT2 - T - 40**

Mounting style Bore size

Notes: select the model when the mounting parts are to be repaired.

**Notes: SCWP2 series is the switch directly mounted model, without mounting components, and the switch body the same with series SCWT2.**

# SCWP2 Series

## How to order

SCWP2 - LB - 40 - B - 50 - T0H - R - M - I

**A** Mounting style

**B** Bore size

**C** Port thread type

**D** Cushion

**E** Stroke length

**F** Switch model

**G** Switch quantity

**H** Option

**I** Accessory

A Mounting style		
00	ISOsymbol	Basic
LB	MS1	Axial foot
FA	MF1	Rod side flange
FB	MF2	Head side flange
CA	MP4	Eye bracket(steel)
CA2	MP4	Eye bracket(aluminium)
CB	MP2	Clevis bracket(steel)
CB2	MP2	Clevis bracket(aluminium)

B Bore size(mm)	
32	φ 32
40	φ 40
50	φ 50
63	φ 63
80	φ 80
100	φ 100

C Port thread type	
Blank	G thread

D Cushion	
B	Both sides cushion (basic)

E Stroke length (mm)(details in stroke length specification)	
--	--

F Switch model				
Lead wire Straight type	lead wire L-type	Contact	Display	lead wire
T0H※	T0V※	Reed	1 color indicator	2 wire
T5H※	T5V※		Without indicator	
T8H※	T8V※		1 color indicator	
T1H※	T1V※	Proximity	1 color indicator	2 wire
T2H※	T2V※			3 wire
T3H※	T3V※		2 color indicator	2 wire
T2WH※	T2WV※			
T2YH※	T2YV※			
T3WH※	T3WV※		1 color indicator	3 wire
T3YH※	T3YV※			
T3PH※	T3PV※		Switch for Strong magnetic field	2 wire
T2YDT※	-		Off delay	2 wire
T2JH※	T2JV※			

※Lead wire length	
Blank	1m(Standard)
3	3m(Optional)
5	5m(Optional)

G Switch quantity	
R	One on rod side
H	One on head side
D	Two
T	Three

H Option	
M	Piston rod material(Stainless steel)

I Accessory		
I	ISO8139	Rod eye
Y	ISO8140	Rod clevis
Y2	ISO8140	Rod clevis
B1		Eye bracket(steel)
B2		Clevis bracket(steel)
B3	AB7	Eye bracket(steel)
B5		Eye bracket(aluminium)
B6		Clevis bracket(aluminium)
B7	AB7	Eye bracket(aluminium)

### ⚠ Cautions for model ( No. selective)

Notes 1: in respect of middle stroke length, fabrication is made with 1mm.

Notes 2: "I" "Y" cannot be used at the same time.

## How to order

### SCWP2-LB-40B-50-T0H-R-MI

- A** Mounting Style: Axial foot
- B** Bore Size: φ40mm
- D** Cushion: Both sides cushion
- E** Stroke length: 50mm
- F** Switch Model: Reed T0H, length of wire is 1m
- G** Switch Quantity: One on rod side
- H** Option: Piston rod material (stainless steel)
- I** Accessory: Rod eye

### How to order

**SCWT2** - **LB** - **40** - **B** - **50** - **T0H** - **R** - **M** - **I**

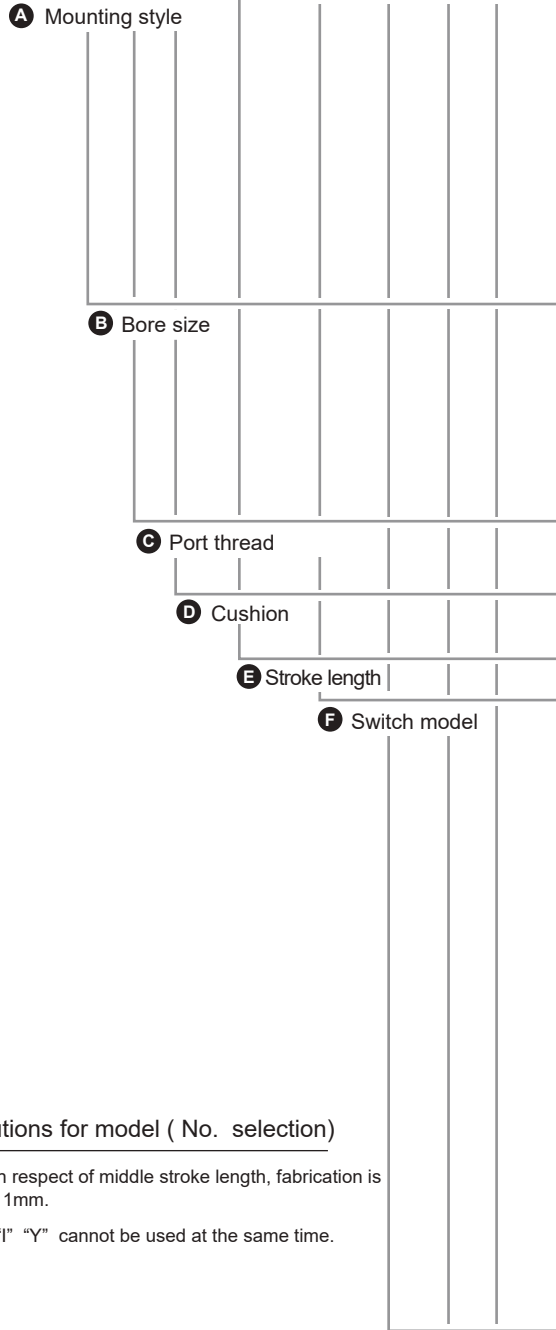

A Mounting style					
00	ISOsymbol	Basic	CB2	MP2	Clevis bracket(aluminium)
LB	MS1	Axial foot	TC	MT4	Center trunnion non adjustable
FA	MF1	Rod side flange	TC2	MT4	Center trunnion adjustable
FB	MF2	Head side flange	TA		Rod side trunnion non adjustable
CA	MP4	Eye bracket(steel)	TA2		Rod side trunnion adjustable
CA2	MP4	Eye bracket(aluminium)	TB		Head side trunnion non adjustable
CB	MP2	Clevis bracket(steel)	TB2		Head side trunnion adjustable

B Bore size(mm)	
32	φ 32
40	φ 40
50	φ 50
63	φ 63
80	φ 80
100	φ 100

C Port thread type	
Blank	G thread

D Cushion	
B	Both sides cushion (basic)

E Stroke length(mm)(details in stroke length specification)

F Switch model				
Lead wire	lead wire	Contact	Display	lead wire
Straight type	L-type			
T0H※	T0V※	Reed	1 color indicator	2 wires
T5H※	T5V※		Without indicator light	
T8H※	T8V※		1 color indicator	
T1H※	T1V※		Proximity	1 color indicator
T2H※	T2V※	3 wires		
T3H※	T3V※			2 color indicator
T2WH※	T2WV※	3 wires		
T2YH※	T2YV※			2 wires
T3WH※	T3WV※	3 wires		
T3YH※	T3YV※			2 wires
T3PH※	T3PV※	1 color indicator		
T2YD※	-	Switch for strong magnetic field	2 wires	
T2YDT※	-	Off delay	2 wires	
T2JH※	T2JV※			

※ Lead wire length	
Blank	1m(Standard)
3	3m(Optional)
5	5m(Optional)

G Switch quantity	
R	One on rod side
H	One on head side
D	Two
T	Three

H Option	
M	Piston rod material(Stainless steel)

I Accessory					
I	ISO8139	Rod eye	B3	AB7	Eye bracket(steel)
Y	ISO8140	Rod clevis	B5		Eye bracket(aluminium)
Y2	ISO8140	Rod clevis	B6		Clevis bracket(aluminium)
B1		Eye bracket(steel)	B7	AB7	Eye bracket(aluminium)
B2		Clevis bracket(steel)			

### ⚠ Cautions for model ( No. selection)

Notes1: in respect of middle stroke length, fabrication is made with 1mm.  
 Notes 2: "I" "Y" cannot be used at the same time.

### How to order

**SCWT2-LB-40B-50-T0H-R-MI**

- A** Mounting Style: Axial foot
- B** Bore Size: φ 40mm
- D** Cushion: Both sides cushion
- E** Stroke length: 50mm
- F** Switch Model: Reed T0H, length of wire is 1m
- G** Switch Quantity: One on rod side
- H** Option: Piston rod material (stainless steel)
- I** Accessory: Rod eye

- G** Switch quantity
- H** Option
- I** Accessory



### Dimensions

- Rod side flange(FA), Head side flange(FB)

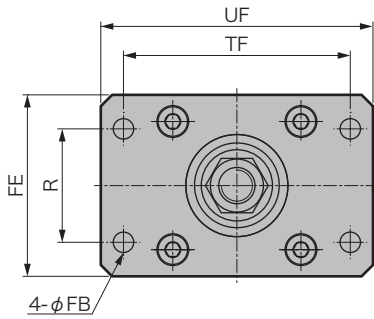

Rod side flange (FA)

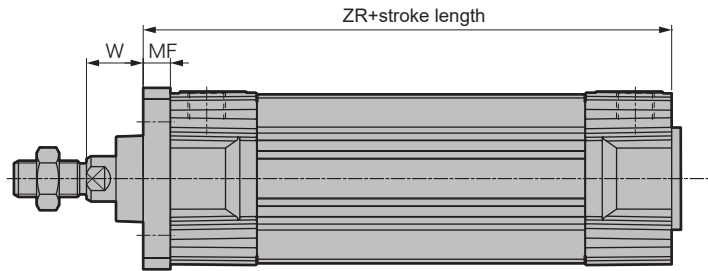

Head side flange(FB)

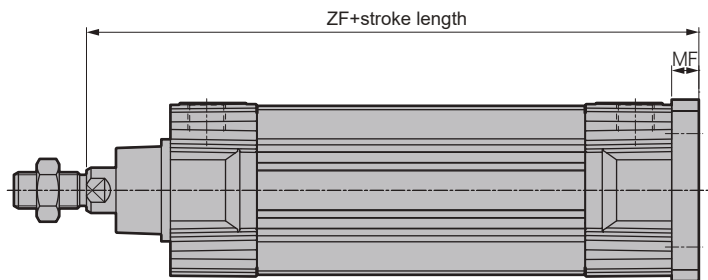

(Unit: mm)

Code	In common use						FA	FB	
	FB	FE	MF	R	TF	UF	W	ZR	ZF
φ 32	7	50	10	32	64	79	16	104	130
φ 40	9	55	10	36	72	90	20	115	145
φ 50	9	70	12	45	90	110	25	118	155
φ 63	9	80	12	50	100	120	25	133	170
φ 80	12	100	16	63	126	153	30	144	190
φ 100	14	120	16	75	150	178	35	154	205

- Eye bracket (steel) (CA), Eye bracket (aluminium) (CA2),  
Clevis bracket (steel)(CB), Clevis bracket (aluminium) (CB2)

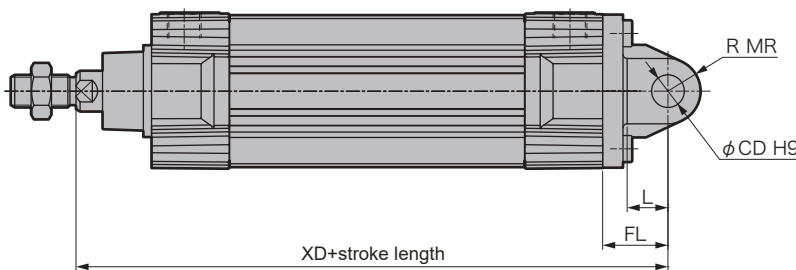

Eye bracket (CA, CA2)

Clevis bracket (CB, CB2)

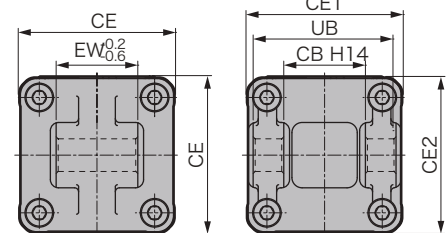

Notes: clevis bracket, a pin, a flat shim and a snap ring are attached

(Unit: mm)

Code	In common use				CA			CB				CA2			CB2					
	CD	FL	L	XD	EW	CE	MR	CB	UB	CE1	CE2	MR	EW	CE	MR	CB	UB	CE1	CE2	MR
φ 32	10	22	12	142	26	47.5	10	26	45	49	47.5	10	26	45	11	26	45	45	45	11
φ 40	12	25	15	160	28	53	12	28	52	57	53	12	28	52	11	28	52	52	52	11
φ 50	12	27	15	170	32	65	12	32	60	65	65	12	32	65	15	32	60	65	65	15
φ 63	16	32	20	190	40	76	16	40	70	76	76	16	40	75	15	40	70	75	75	15
φ 80	16	36	20	210	50	95	16	50	90	95	95	16	50	95	18	50	90	95	95	18
φ 100	20	41	25	230	60	114	20	60	110	116	114	20	60	115	18	60	110	115	115	18

# SCWT2 Series

## Dimensions

● Basic(00)

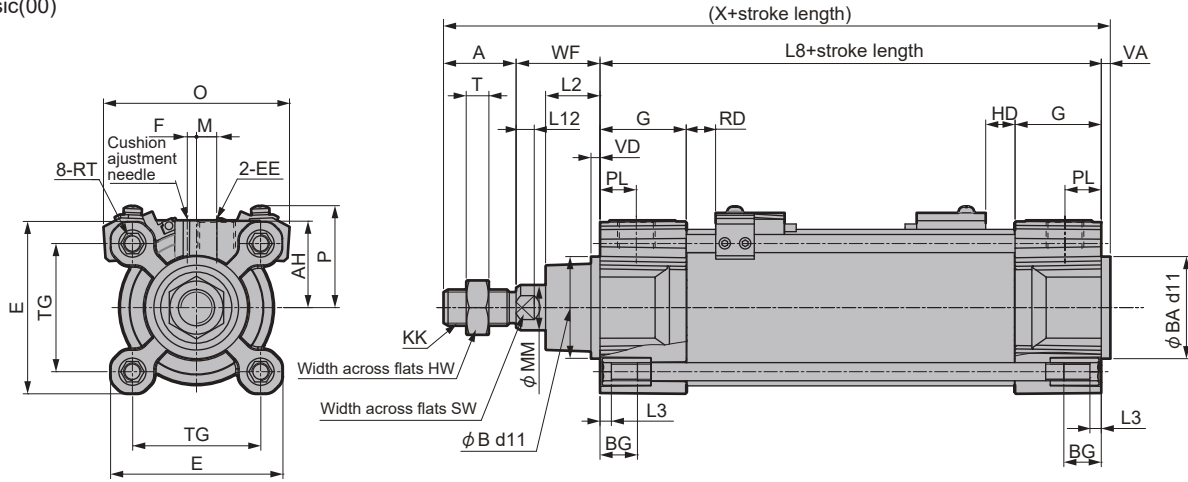

(Unit: mm)

Code	Basic(00)basic dimensions																			
Bore size	A	B/BA	BG	E	AH	EE	F	G	HW	KK	L2	L3	L8	L12	M	MM	SW	PL	RT	T
φ32	22	30	16	47.5	24.3	G1/8	-6.7	33	17	M10×1.25	15	5	94	6	4.9	12	10	13	M6	6
φ40	24	35	16	53	27	G1/4	-10	35.8	18	M12×1.25	17	5	105	8	5.5	16	13	14	M6	6
φ50	32	40	16	65	33	G1/4	0.6	37	24	M16×1.5	24	5	106	8	7	20	17	14	M8	10
φ63	32	45	16	76	38.5	G3/8	3	38.3	24	M16×1.5	24	5	121	8	9	20	17	16	M8	10
φ80	40	45	17	95	48	G3/8	0	40	30	M20×1.5	30	6	128	11	12	25	22	16	M10	12
φ100	40	55	17	114	57.5	G1/2	4.5	43.2	30	M20×1.5	33	6	138	11	12	25	22	18	M10	12

Code	With switch									
	T0, T5, T2, T3	T2W, T3W	RD	HD	RD	HD	RD	HD		
Bore size	TG	VA/VD	WF	X	O	P	RD <td>HD <td>RD <td>HD</td> </td></td>	HD <td>RD <td>HD</td> </td>	RD <td>HD</td>	HD
φ32	32.5	4	26	146	58	38	4.5	4.5	7	7
φ40	38	4	30	163	64	40	4.5	9.5	7	12
φ50	46.5	4	37	179	72	42	5.5	7.5	8	9.5
φ63	56.5	4	37	194	83	46	10	15.5	12.5	17.5
φ80	72	4	46	218	103	56	14.5	14.5	17	17
φ100	89	4	51	233	120	63	16.5	16.5	18.5	18.5

● Axial foot(LB)

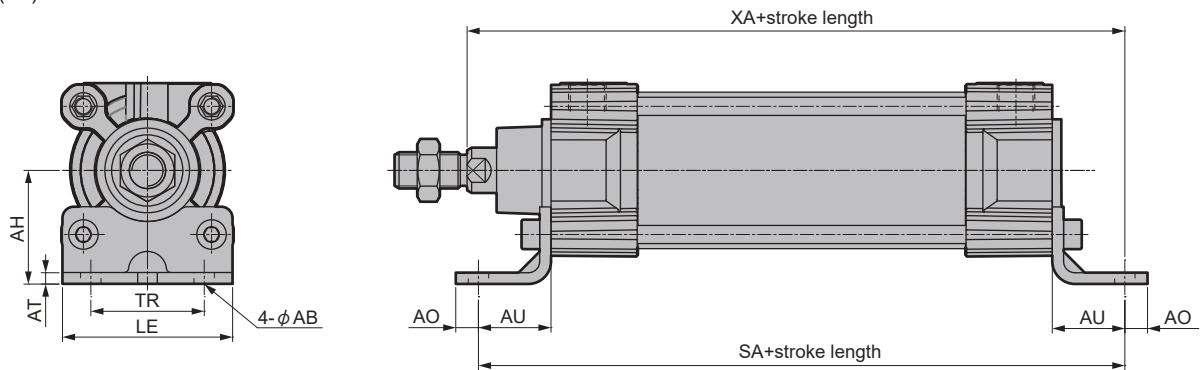

(Unit: mm)

Bore size	AB	AH	AO	AT	AU	LE	SA	TR	XA
φ32	7	32	8	4	24	46	142	32	144
φ40	9	36	10	4	28	52	161	36	163
φ50	9	45	10	5	32	65	170	45	175
φ63	9	50	10	5	32	75	185	50	190
φ80	12	63	13	6	41	94	210	63	215
φ100	14.5	71	15	6	41	114	220	75	230

### Dimensions

- Rod side flange(FA), Head side flange(FB)

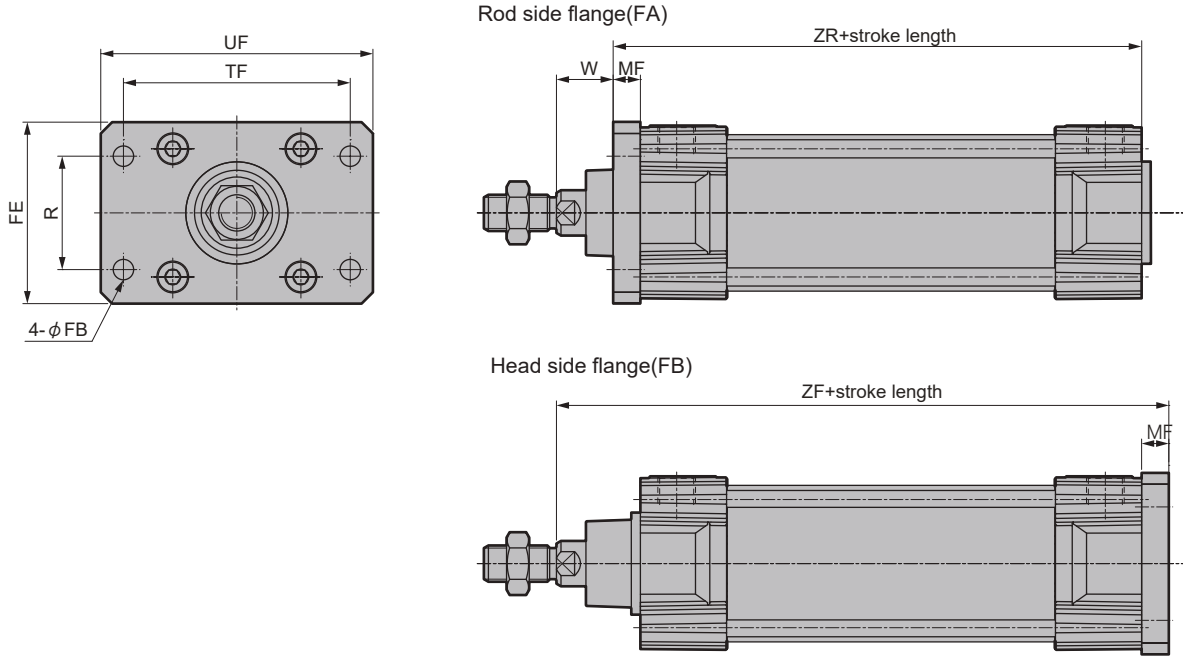

(Unit: mm)

Code	In common use						FA	FB	
	Bore size	FB	FE	MF	R	TF	UF	W	ZR
φ 32	7	50	10	32	64	79	16	104	130
φ 40	9	55	10	36	72	90	20	115	145
φ 50	9	70	12	45	90	110	25	118	155
φ 63	9	80	12	50	100	120	25	133	170
φ 80	12	100	16	63	126	153	30	144	190
φ 100	14	120	16	75	150	178	35	154	205

- Eye bracket (steel) (CA), Eye bracket (aluminium) (CA2)
- Clevis bracket (steel) (CB), Clevis bracket (aluminium) (CB2)

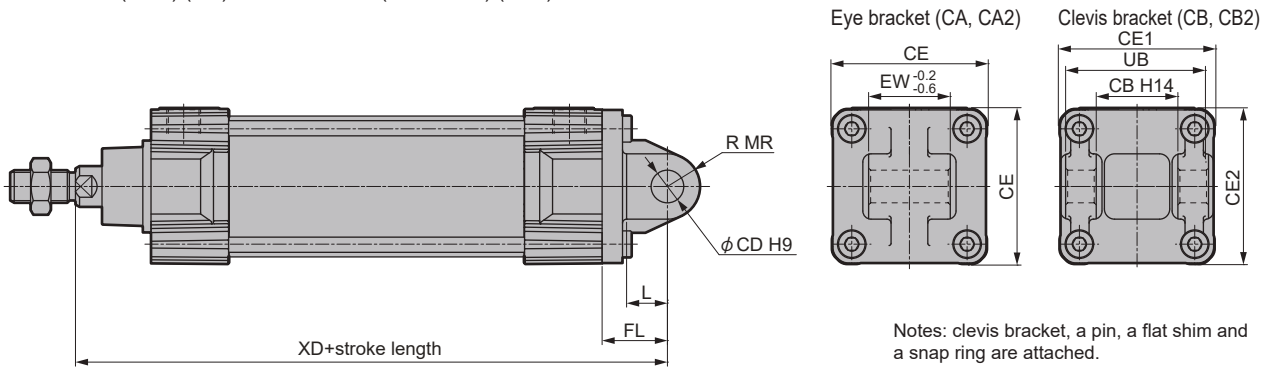

Notes: clevis bracket, a pin, a flat shim and a snap ring are attached.

(Unit: mm)

Code	In common use				CA			CB				CA2			CB2					
	Bore size	CD	FL	L	XD	EW	CE	MR	CB	UB	CE1	CE2	MR	EW	CE	MR	CB	UB	CE1	CE2
φ 32	10	22	12	142	26	47.5	10	26	45	49	47.5	10	26	45	11	26	45	45	45	11
φ 40	12	25	15	160	28	53	12	28	52	57	53	12	28	52	11	28	52	52	52	11
φ 50	12	27	15	170	32	65	12	32	60	65	65	12	32	65	15	32	60	65	65	15
φ 63	16	32	20	190	40	76	16	40	70	76	76	16	40	75	15	40	70	75	75	15
φ 80	16	36	20	210	50	95	16	50	90	95	95	16	50	95	18	50	90	95	95	18
φ 100	20	41	25	230	60	114	20	60	110	116	114	20	60	115	18	60	110	115	115	18

# SCWT2 Series

## Dimensions

- Center trunnion non adjustable (TC), Rod side trunnion non adjustable (TA), Head side trunnion non adjustable (TB)  
Center trunnion adjustable (TC2), Rod side trunnion adjustable (TA2), Head side trunnion adjustable (TB2)

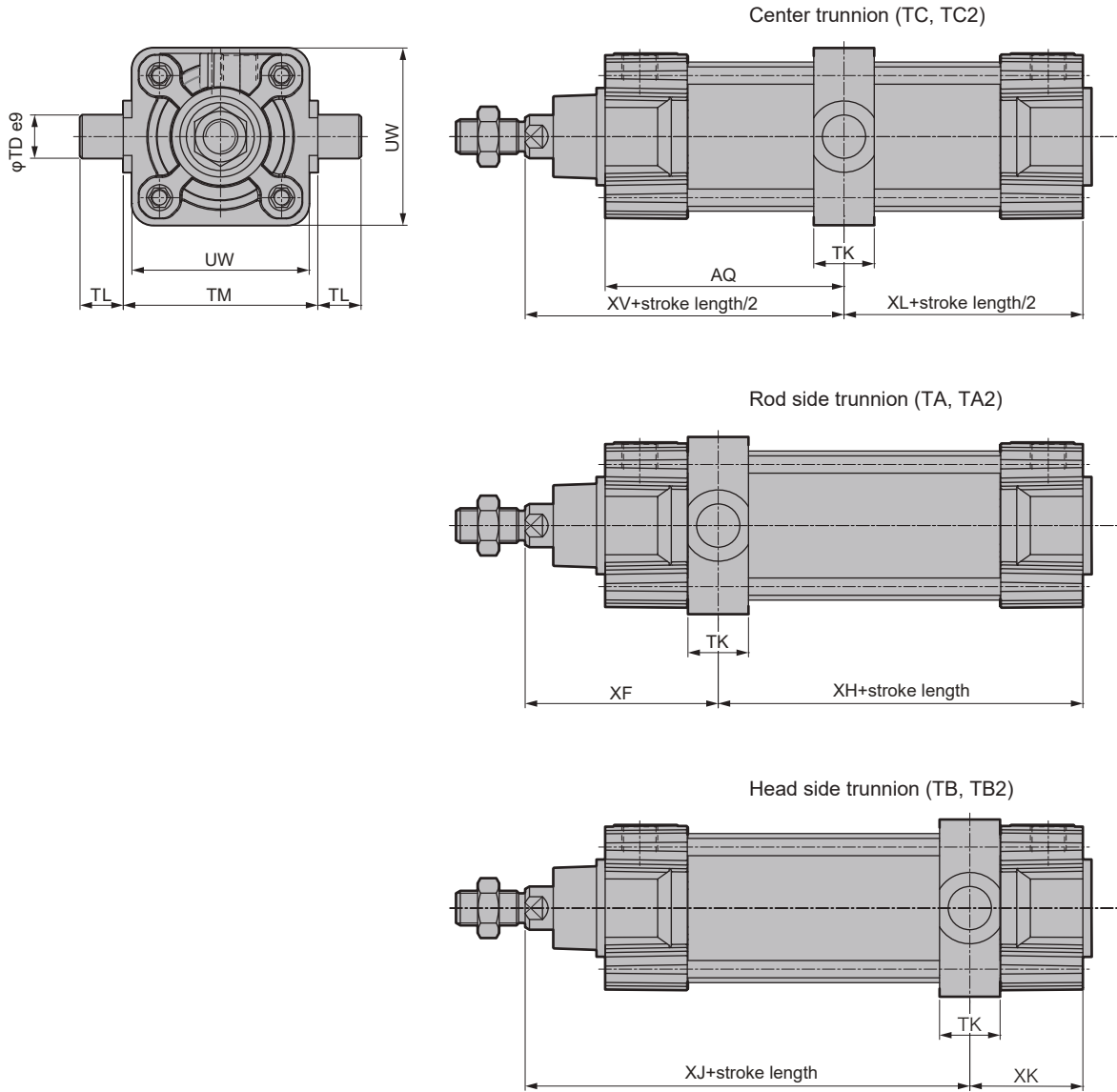

(Unit: mm)

Code	In common use			TC				TA				TB			
	TM	TL	TD	XV	XL	TK	UW	XF	XH	TK	UW	XJ	XK	TK	UW
φ 32	50	12	12	73	47	17	47	67.5	52.5	17	47	78.5	41.5	17	47
φ 40	63	16	16	82.5	52.5	22	57	76.8	58.2	22	57	88.2	46.8	22	57
φ 50	75	16	16	90	53	22	67	85	58	22	67	95	48	22	67
φ 63	90	20	20	97.5	60.5	28	82	89.3	68.7	28	82	105.7	52.3	28	82
φ 80	110	20	20	110	64	34	100	103	71	34	100	117	57	34	100
φ 100	132	25	25	120	69	40	121	114.2	74.8	40	121	125.8	63.2	40	121

TC2				TA2				TB2			
XV	XL	TK	UW	XF	XH	TK	UW	XJ	XK	TK	UW
73	47	15	46	66.5	53.5	15	46	79.5	40.5	15	46
82.5	52.5	20	59	75.8	59.2	20	59	89.2	45.8	20	59
90	53	20	69	84	59	20	69	96	47	20	69
97.5	60.5	25	84	87.8	70.2	25	84	107.2	50.8	25	84
110	64	25	102	98.5	75.5	25	102	121.5	52.5	25	102
120	69	30	125	109.2	79.8	30	125	130.8	58.2	30	125

## Accessory dimensions

● Rod clevis (Y)

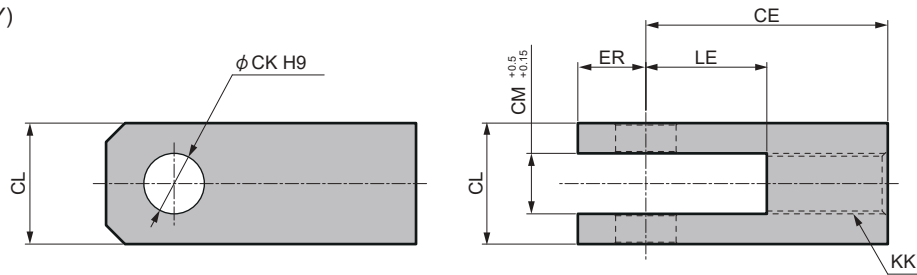

Note: with shaft pin, flat shim and cotter pin

Bore size	CE	CK	CM	CL	ER	KK	LE	Model
φ 32	40	10	10	19	11.5	M10 × 1.25	20	SCWP2-Y-32
φ 40	48	12	12	24	13	M12 × 1.25	24	SCWP2-Y-40
φ 50,63	64	16	16	32	18	M16 × 1.5	32	SCWP2-Y-50
φ 80,100	80	20	20	40	24	M20 × 1.5	41	SCWP2-Y-80

● Rod clevis (Y2)

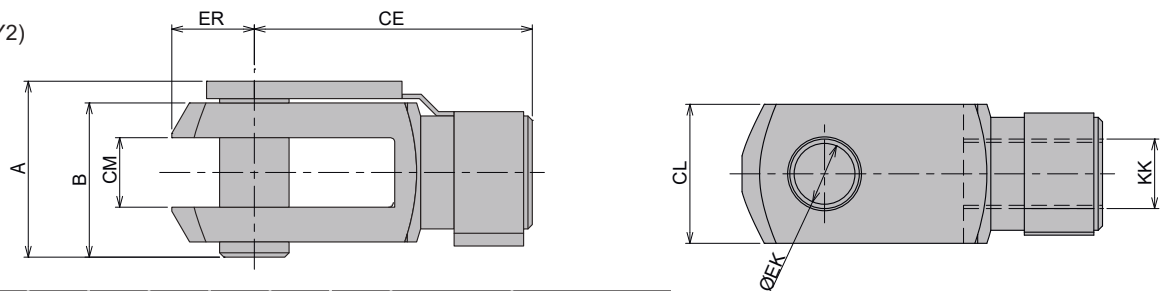

Bore size	CE	EK	CM	CL	ER	A	B	KK	Model
φ 32	40	10	10	20	12	26	23	M10 × 1.25	SCWP2-Y2-32
φ 40	48	12	12	24	14	32	28	M12 × 1.25	SCWP2-Y2-40
φ 50,63	64	16	16	32	19	40	36	M16 × 1.5	SCWP2-Y2-50
φ 80,100	80	20	20	40	25	48	44	M20 × 1.5	SCWP2-Y2-80

● Rod eye (I)

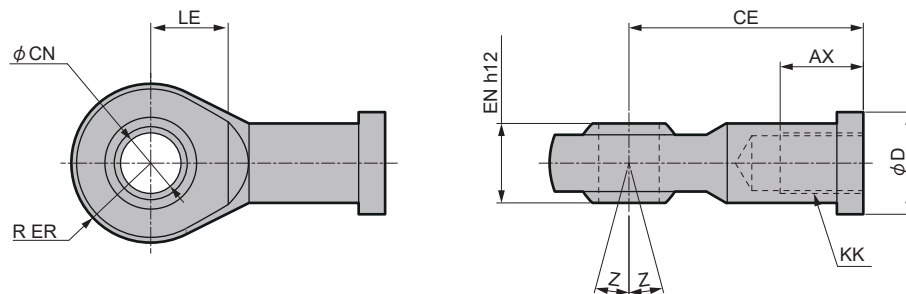

Bore size	AX	CE	CN	D	EN	ER	KK	LE	Z	Model
φ 32	20	43	10	19	14	14	M10 × 1.25	15	13	SCWP2-I-32
φ 40	22	50	12	22	16	16	M12 × 1.25	17	13	SCWP2-I-40
φ 50,63	28	64	16	27	21	21	M16 × 1.5	22	15	SCWP2-I-50
φ 80,100	33	77	20	34	25	25	M20 × 1.5	26	15	SCWP2-I-80

● Pin

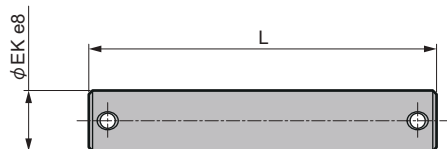

Notes: with flat washer and cotter pin

For clevis bracket (for CB)

Bore size	EK	L	Model
φ 32	10	62	SCWP2-P1-32
φ 40	12	70	SCWP2-P1-40
φ 50	16	78	SCWP2-P1-50
φ 63	16	92	SCWP2-P1-63
φ 80	20	112	SCWP2-P1-80
φ 100	20	132	SCWP2-P1-100

For rod clevis (for Y)

Bore size	EK	L	Model
φ 32	10	36	SCWP2-P2-32
φ 40	12	42	SCWP2-P2-40
φ 50,63	20	54	SCWP2-P2-50
φ 80,100	20	62	SCWP2-P2-80

Notes: The dimensions of **SCWP2** are the same with **SCWT2**

## Accessory dimensions

Notes: The dimensions of **SCWP2** are the same with **SCWT2**

- Eye bracket (steel) (B1), Eye bracket (aluminium) (B5)  
Clevis bracket (steel) (B2), Clevis bracket (aluminium) (B6)

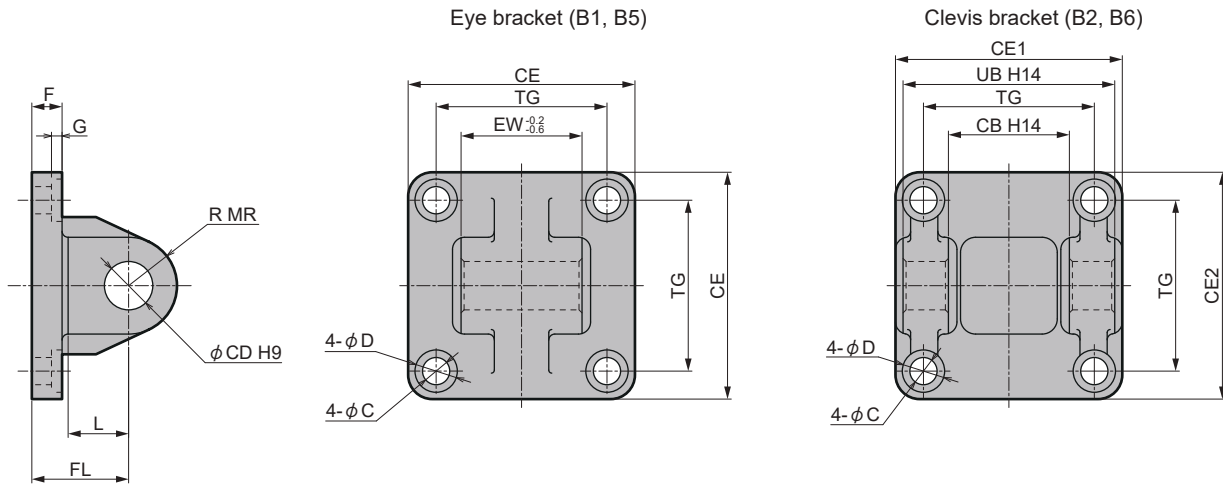

Notes: clevis bracket, a pin, a flat shim and a snap ring are attached

Bore size	C	CB	CD	CE	CE1	CE2	D	EW	F	G	FL	L	MR	TG	UB	Model B1	Model B5	Model B2	Model B6
ϕ 32	6.6	26	10	46	49	46	11	26	8	5.5	22	12	10	32.5	45	SCWP2-B1-32	SCWP2-B5-32	SCWP2-B2-32	SCWP2-B6-32
ϕ 40	6.6	28	12	52	57	52	11	28	8	5.5	25	15	12	38	52	SCWP2-B1-40	SCWP2-B5-40	SCWP2-B2-40	SCWP2-B6-40
ϕ 50	9	32	12	65	65	65	14	32	10	6.5	27	15	12	46.5	60	SCWP2-B1-50	SCWP2-B5-50	SCWP2-B2-50	SCWP2-B6-50
ϕ 63	9	40	16	75	75	75	14	40	10	6.5	32	20	16	56.6	70	SCWP2-B1-63	SCWP2-B5-63	SCWP2-B2-63	SCWP2-B6-63
ϕ 80	11	50	16	95	95	95	17.5	50	14	10	36	20	16	72	90	SCWP2-B1-80	SCWP2-B5-80	SCWP2-B2-80	SCWP2-B6-80
ϕ 100	11	60	20	114	116	114	17.5	60	14	10	41	25	20	89	110	SCWP2-B1-100	SCWP2-B5-100	SCWP2-B2-100	SCWP2-B6-100

- Eye bracket (steel) (B3)  
Eye bracket (aluminium) (B7)

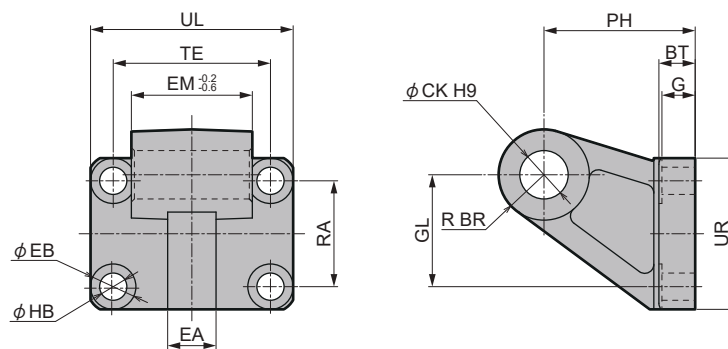

Bore size	BR	BT	CK	EA	EB	EM	G	GL	HB	PH	RA	TE	UL	UR	Model B3	Model B7
ϕ 32	10	8	10	10	11	26	7	21	6.6	32	18	38	51	31	SCWP2-B3-32	SCWP2-B7-32
ϕ 40	11	10	12	12	11	28	9	24	6.6	36	22	41	54	35	SCWP2-B3-40	SCWP2-B7-40
ϕ 50	12	12	12	16	15	32	11	33	9	45	30	50	65	45	SCWP2-B3-50	SCWP2-B7-50
ϕ 63	15	12	16	16	15	40	11	37	9	50	35	52	67	50	SCWP2-B3-63	SCWP2-B7-63
ϕ 80	15	14	16	20	18	50	13	47	11	63	40	66	86	60	SCWP2-B3-80	SCWP2-B7-80
ϕ 100	19	15	20	20	18	60	14	55	11	71	50	76	96	70	SCWP2-B3-100	SCWP2-B7-100

# Notes

## In design and model selection

### 1. Specifications confirmation

#### ⚠ Warning

- The products shall be used within the specifications. The product described in the production manual is only designed for being used in compressed air system. Do not use it beyond pressure or temperature; otherwise, damage or abnormal operation may be caused. (Refer to the specifications). When compressed air and fluids out of low oil pressure are used, please negotiate with the Company.

### 2. Safety design

#### ⚠ Warning

- When strength of the cylinder is changed due to twisting of sliding components of the machinery, the piston rod may be out of place. The hands or feet may be damaged or the machine maybe damaged. Therefore, the machine shall be adjusted in design to ensure smooth operation, and no harm is caused to human body.
  - The protection cover shall be mounted when human safety is endangered. When driving of the cylinder endangers human safety, the protection cover shall be mounted. The structure preventing from accessing driving scope of the cylinder or inaccessible to human body shall be used.
  - Please consider possibility of fault of the dynamics power. Air pressure, oil pressure, power and other dynamics power device are designed and optimized to prevent human injury or device damage in case of fault of these dynamics.
  - Out-of-place design shall be made for the loop. The directional control valve of the exhausting center type is used to drive the cylinder or start with the remaining pressure of the exhausting loop, and when the piston is pressurized with air exhausted from the cylinder, the driven objects fly out at high speed. At this moment, hands and feet may be injured or the machine may be damaged; therefore, the out-of-place loop must be designed.
  - Consider operation in case of emergency stop. Design properly, ensure that safety device starts in case of emergency stop or power failure and other system abnormality, and human body, equipment and device are not impaired due to operation of the cylinder.
  - Please consider operation conditions when starting after emergency stop and abnormal stop. To prevent human injury or device damage in restarting, design properly. To restore the cylinder to the starting position, design a safe control device.
  - Necessary measures must be adopted to cause negative influences on human body or objects in case of fault.
- #### ⚠ Caution
- Mount the "pressure switch" and "remaining value exhausting valve" at the compressed air supply side of the device.
    - The pressure switch is set at failure operation if not reaching the setting pressure. The remaining pressure exhausting valve exhausts remaining compression pressure to prevent accident by operation of the pneumatic components.

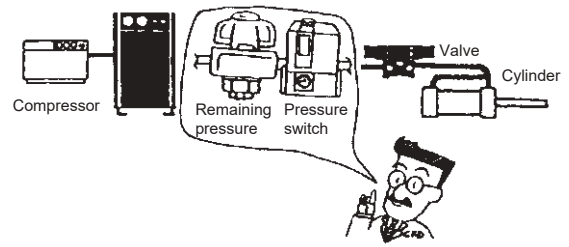

### 3. Design according to purpose

#### ⚠ Caution

- When the deceleration loop or the cushion device is used. The driven objects are speedy or heavy, only cushion of the cylinder cannot absorb the shock; therefore, the deceleration loop shall be designed before the cushion or the cushion shall be adopted externally to lower impact. At this moment, please consider rigidity of the machinery.
- When inertia force and vibration etc. are generator. When cylinder is mounted on mobile objects (X-axis module, pallet etc.), the mobile objects generates inertia force and vibration when stopping, and please consider these factors in designing.
- On middle stop. The 3-position mid-sealing direction control valve is used to stop the cylinder piston in the middle, due to air compression, precise stop cannot be realized like the low-pressure oil. Nevertheless, the valve or cylinder cannot ensure zero air leakage, so it cannot keep at the stop position for a long time. To keep at the stop position on a long-term basis, negotiate with the Company.

### 4. Operation environment

#### ⚠ Warning

- Do not mount the product with rain, water, sunshine and more moisture.
- Do not use the product with possible corrosive environment. Otherwise, the product may be damaged and the operation is abnormal.
- The protection cover shall be installed at dusty site or sites with water drips, oil drips, cooling liquid and spraying sites. Brute force is used in dusty environment. Anti-cutting oil model shall be used under liquid spraying environment.
- When environment temperature is lower than 5°C, abnormal operation by moisture freezing in loop may be caused; therefore, moisture shall be removed to avoid freezing.

### 5. Durability

#### ⚠ Warning

- The durability shall be subject to operation conditions and machine features.

### 6. Air

#### ⚠ Warning

- The compressed air shall be clean and compressed air. Do not make compressed air with synthesized oil (including chemicals and organic solvents), salt and corrosive gas; otherwise, chemicals and organic solvents, salt and corrosive gas; otherwise,

## ⚠ Caution

- Please use drying compressed air not producing condensation water in the piping.

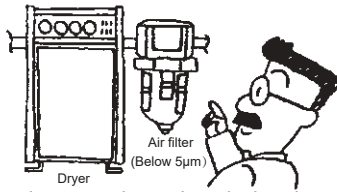

- Condensation water is produced when internal temperature within the air compression tubing and pneumatic components is lowered.
- When the piping volume is larger than the cylinder volume (atmosphere conversion volume), when electromagnetic valve is used to switch, compressed air within the cylinder cannot be exhausted completely, and water drips after moisture condensation become condensation water.
- Condensation water flows into air pipe within pneumatic components, and results in instantaneous blocking and abnormal operation.
- Condensation water results in rusting and causes fault of the pneumatic components.
- Condensation water flushes the lubricant and results in poor lubrication.
- The standard pneumatic components are not applicable to ultra-drying air. Please use ultra-drying air components.
  - The ultra-drying compressed air shortens service life of pneumatic components.
  - Please use electromagnetic valve driven by DC voltage.
- Please use compressed air without oxidizing oil content, tar and carbon etc. of the air compressor.
  - Oxidizing oil content, tar or carbon enters and is attached on the interior of the pneumatic components, which increases resistance of the sliding components and results in poor operation.
  - Oxidizing oil content, tar or carbon is mixed with lubricant and wears sliding component of the pneumatic components.
- Please use compressed air without solid foreign
  - Solid foreign objects in the compressed air entering interior of pneumatic components results in wearing and attachment of the sliding component, and mount the air filter with filtering precision of below 5µm.
  - Perform compressor maintenance and inspection periodically.

## 7. Use

### ⚠ Caution

- The products have been initially lubricated and can be used under self-lubricating status. When oil is supplied, please use ISO-VG32 turbine oil (no addition). If interrupted during the process, insufficient initial lubricant results in poor operation, and feed oil continuously. Self-lubricating or oil feeding lubricating is applied to the pneumatic equipment, and strict management is carried out for the corresponding lubricating mode.
- The piston is not used within the range of not causing rupture at the end of the travel. As for piston with inertia force, when it stops due to striking the cylinder cover at the end of the travel, please use within the range of absorbing energy.
- Till the end of the cylinder travel, please make the air cushion valid, and use within the range of absorbing energy; otherwise, rupture may occur.
- Please mount regulating valve on the cylinder. Please use within the speed range of the piston.
- Please mount the middle support on the long-stroke length piston. To prevent piston rod drooping, cylinder barrel twisting and vibration or damage to piston rod by external load, please mount the middle support.
- Please use within max stroke length of the supporting form.

- Using several cylinders simultaneously should be avoided. Otherwise, synchronized operation cannot be maintained and the piston rod is not twisted, and operation is sub-standard. When synchronized operation is required, high-rigidity guide must be mounted.
- When earring and trunnion are mounted, please use after confirming that full travel of the cylinder does not cause interference and it can rotate back freely.
- When movement direction of the load is changed with action, the cylinder shall be of swaying cylinder with specific angle (earring and trunnion). Besides, when mounted, the rod end connection component shall have the same movement direction of the cylinder body.
- Do not connect the fixing cylinder and the arm in circling movement. At this moment, please connect with swaying cylinders.

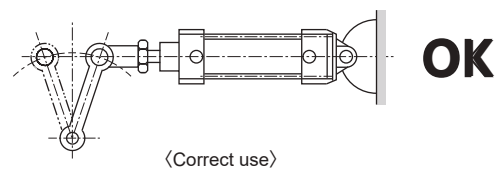
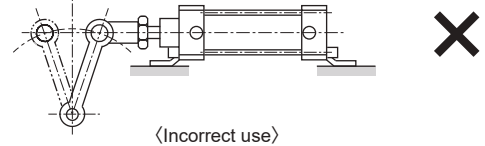

- To prevent rupture of piston rod screws, wear and burning loss of the shaft sleeve, the universal joint or simple universal joint is used to connect end of the piston rod to prevent twisting at any position of the stroke length.
- If the clearance between earring or trunnion and the corresponding bear is excessive, the pin or shaft may suffer bending force. Therefore, the clearance cannot be excessive. (Recommended to use with H10/e8)
- In the Figure above, when the height H from mounting surface of the bearing supporting element and the bearing is larger, due to operation by the cylinder force, the mounting component of the support yield greater

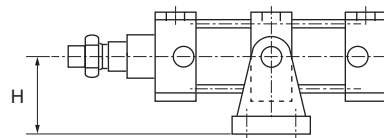

- Sealing element sliding component or washer fixing component of low oil pressure cylinder may leak trace oil. When it is used at interior of the vacuum container or the oil-resistant site, please use carefully.

## 8. Guarantee space

### ⚠ Caution

- Please ensure that there is space for assembling, disassembling, wiring and piping operation around the cylinder.

## 9. Cautions on use of instruction manual

### ⚠ Caution

- Please mark maintenance conditions of the devices in the instruction manual. Under some operation conditions, environment and maintenance conditions, the production functions may be impaired and safety cannot be ensured. If it is properly maintained, the product functions are fully yielded.

## 1. Installation

### ⚠ Caution

#### ■ Assembling tips for mounting bracket

The mounting bracket are delivered with the products, and the tightening torque shall be in accordance (Unequal tightening may cause unstable operation). Besides, the trunnion models (TC, TA, TB) are delivered after installation of the trunnion.

Bore size	Tightening torque
φ 32, φ 40	4.4N·m
φ 50, φ 63	9.8N·m
φ 80, φ 100	21.1N·m

#### ■ Before piping, do not remove the cylinder package or the piping orifice dustproof seal.

- Otherwise, foreign objects may enter interior of the cylinder from the piping orifice and result in error operation.

#### ■ Protection measures shall be mounted when the cylinder is installed to prevent load falling or turnover.

#### ■ When the cylinder mass is more than 15Kg, hanger shall be used.

#### ■ Do not place objects on the cylinder barrel and the sliding component of piston rod to avoid collision and causing damage and indenture.

Tolerance of the cylinder bore is precise, and even the tiny deformation results in poor operation. Damage or indenture of sliding component of the piston rod may damage the sealing element and result in air leaking.

#### ■ When movement direction of the load is not parallel with axis of the piston rod, the piston rod and the cylinder body may twist, and the piston rod is out of place. It may cause burning loss and rupture etc. Please ensure that the axis of the piston rod is consistent with movement direction of load.

#### ■ Measures are adopted to prevent burning loss of the rotary components.

Apply lubricating grease at the rotary component (pin etc.) and prevent burning loss

## 2. Piping

### ⚠ Caution

#### ■ In piping, please operate by referring to the instruction manual, and do not confuse the air orifice.

- Otherwise, it may result in error operation.

#### ■ Sealing tape twisting method in piping connection: within the interior side more than 2 teeth from the front end of the piping screws, twist clockwise.

- If the sealing tape exposes rod piping screw, the sealing tape may break due to twisting, and the remaining part leaves interior and result in fault.



#### ■ Prevent the piping connecting with the cylinder from being separated due to vibration, looseness and tension. Prevent the piping connecting with the cylinder from being separated due to vibration, looseness and tension.

- Separation of piping at the exhausting side of the pneumatic loop.
- With the jack catch held, the jack catch will be released to cause danger.

#### ■ When nylon or PU pipe is used, please notice the following:

- Under the spraying environment, please use flame-resistant pipe or metallic pipe.

#### ■ Galvanizing pipe, stainless pipe, nylon pipe, rubber and other anti-corrosion materials shall be used as pipe materials.

#### ■ In piping connection, fasten with proper fastening torque.

- It prevents air leaking and screw damage.
- To avoid damage to screws, after tightening with screws, fasten with tools.



[Reference value]

Please refer to the instruction manual.

Piping screws	Fastening torque (N · m)
M3	0.3~0.6
M5	1 ~ 1.5
Rc 1/8	3 ~ 5
Rc 1/4	6 ~ 8
Rc 3/8	13 ~ 15
Rc 1/2	16 ~ 18
Rc 3/4	19 ~ 40
Rc 1	41 ~ 70

#### ■ During piping, before connecting with the pneumatic components, perform blowing and cleaning.

- In the process of piping, foreign objects entering the interior shall be prevented from entering interior of pneumatic components.

## 3. Confirmation before

### ⚠ Warning

#### ■ Before operation, check mounting and fastening of the load and cylinder involve looseness and abnormality.

#### ■ Do not use before confirming that the components are normal.

Connect compressed air and power after being mounted, repaired or modified, timely test the functions and leaking correctly, and confirm the mounting is normal.

#### ■ Confirm if disturbance of the machine and the operation system is abnormal or not.

#### ■ Please confirm if operation of the pressure device is abnormal or not, and set after the pressure has been increased slowly.

#### ■ The exhausting side is started under the atmosphere conditions, and the piston rod out of place may result in danger. Start under pressurized cylinder chamber of the exhausting cylinder.

### ⚠ Caution

#### ■ When piping is finished and supplies compressed air, please confirm that the air connected by the pipe does not leak.

- Apply leaking liquid to the piping connection with brush, and check whether air leaks.

#### ■ Read the instruction manual.

Use after reading carefully. Keep the instruction manual properly for future reference.

## 4.Adjustment

### ⚠ Warning

- When flow regulating valve is used to adjust speed, open the needle valve slowly from closing conditions for adjustment. When adjusting speed under opening conditions, the piston rod involves hazards of deviation.
- The cushion of air cushion has been well adjusted in delivery, and re-adjust with cushion needle valve according to load and piston speed.  
Slowly open the needle valve from the closing conditions and adjust the cushion. If the cushion needle valve is too loosened, it may lose the cushion effects and may be separated. After the adjustment, fasten the needle valve (hexagonal nuts). Please use within the permissible scope of dynamics. When used beyond the permissible use, it may damage the products.
- When driving the cylinder, do not enter the scope of driving of the cylinder or place the hands into it.

### ⚠ Caution

- Scope of operation of air cushion has been well adjusted.
  - When scope of operation of the air cushion is changed according to load, please adjust with the cushion needle valve. Screw off (turn leftwards) the needle valve to relieve cushion.

## In operation and maintenance

### 1.Maintenance

#### ⚠ Warning

- Please refer to the instruction manual carefully for inspection and maintenance.  
Incorrect operation may result in damage to components and devices or abnormal operation.

#### ⚠ Caution

- Maintain and manage correctly, and perform daily inspection and periodic inspection as scheduled.
  - Improper maintenance and management may result in impaired product functions, shortened service life, damaged products, and incorrect operation and other faults.
- ① Pressure management of supplied compressed air
  - Whether the supply compressed air reaches the setting pressure?  
In the process of device, whether the pressure gauge indicates the setting pressure?
- ② Management of air filter
  - Whether condensation water is drained out as usual?  
Whether dirt of the filtering cup and filtering screen is normal?
- ③ Management of leaking of compressed air of the tubing connection
  - In particular, the mobile connector is normal or not?
- ④ Management of action conditions of electromagnetic valve
  - Whether action is delayed and emission conditions are normal?
- ⑤ Management of action status of pneumatic actuator
  - Whether action is smooth?  
Whether the end stop conditions are normal?  
The connection with load is normal or not?
- ⑥ Management of atomized lubricator
  - Whether oil volume adjustment is normal?
- ⑦ Management of lubricant
  - Whether the supplemented lubricant is official?

- Do not use with excessive air leaking or abnormal operation of components.
  - Please connect compressed air and power supply after repairing or reconstruction. Test functions and leakage correctly, and confirm whether the operation is normal.
- Please confirm whether operation is normal in starting after long-term idling.
- When performing periodic inspection, replace with the wearing parts beyond the rated service life with new ones.  
Do not use wearing parts with storage period for over 5 years.
- Place the wearing parts at the shade site without the sunshine.

### 2.Disassembling

#### ⚠ Warning

- Disassembling components and compressed air supply and discharge  
Please confirm that the driven objects are provided with anti-falling and anti-out-of-control handling, and cut off supply air and power. Exhaust compressed air in the system and disassemble components. Restart, confirm whether the deviation measures are in place and operate carefully.

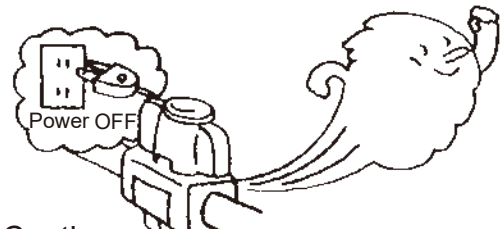

#### ⚠ Caution

- Before disassembling the cylinder, please adopt protection measures to prevent load falling or overturning.

### 3.Disassembling and assembling

#### ⚠ Warning

- After disassembling from the device, disassemble the cylinder.
- The professional operator is responsible for assembling and disassembling.  
After disassembling and re-assembling, perform leaking and action testing, and assemble after everything is normal.
- In disassembling single-action cylinder, the component may deviation under action of spring, and please notice.
- Assembling and disassembling of the rod cover shall be operated with pinchers (C-shaped retainer mounting tool).
- When proper pincher are used (C-shaped retaining mounting tool), the retaining ring may fall down in front of the pincher and deviation to cause human injury and damage to surrounding components.  
Please operate carefully.  
Besides, when mounted, confirm that the retainer ring has been mounted into the retainer slot, and supply air.

#### ⚠ Caution

- When performing wearing parts replacement and other operation, please assemble and disassemble on the dustless environment, check the component functions, and confirm whether they are under normal conditions.

---

MEMO

---

---

MEMO

---

---

MEMO

---

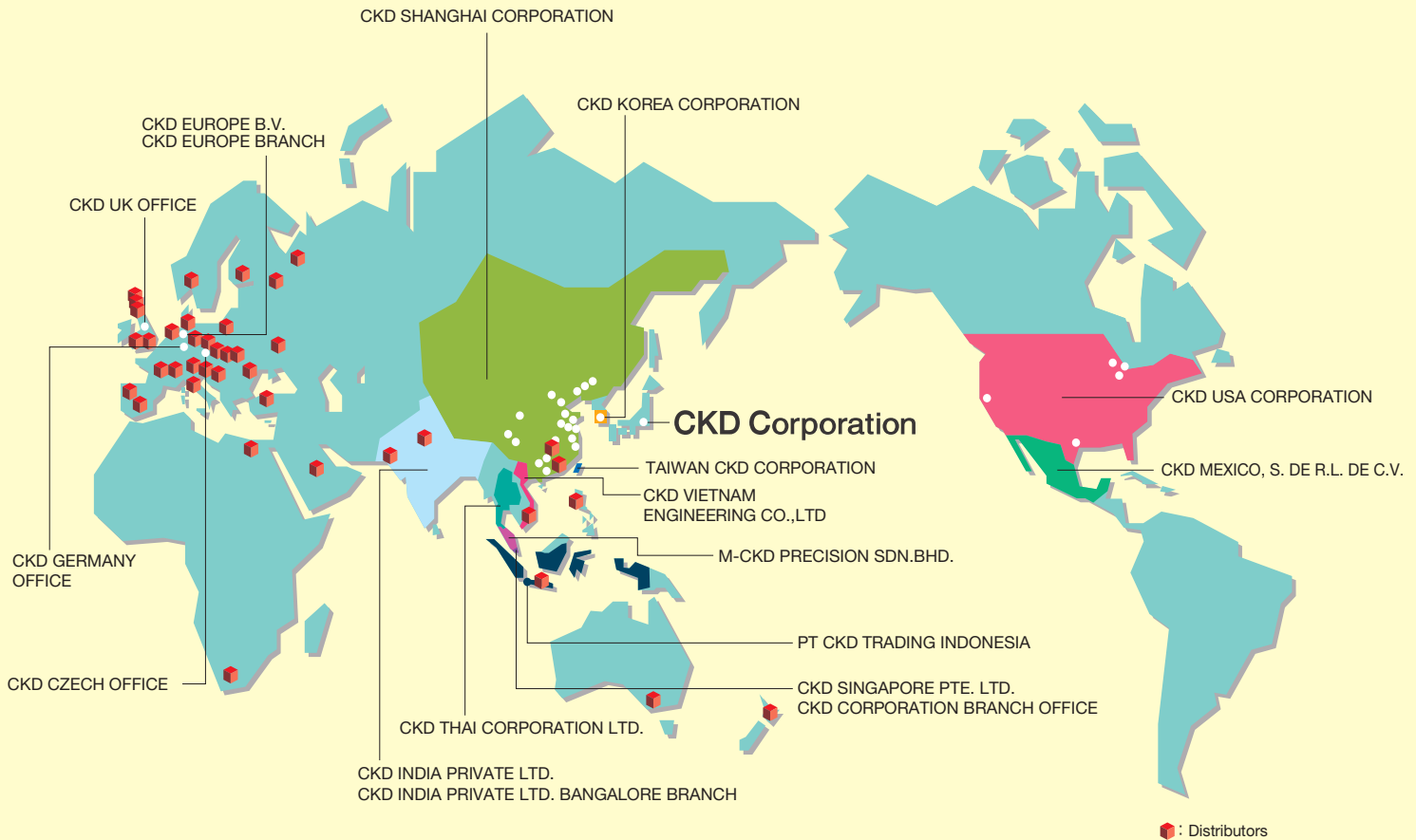

## CKD Corporation

Website <http://www.ckd.co.jp/>

### Europe

#### CKD EUROPE B.V.

Beechavenue 125A, 1119 RB Schiphol-Rijk, The Netherlands  
PHONE +31-23-554-1490  
GERMANY OFFICE

#### CKD CORPORATION EUROPE BRANCH

##### ● SALES HEADQUARTERS

Beechavenue 125A, 1119 RB Schiphol-Rijk, The Netherlands  
PHONE +31-23-554-1490  
CZECH OFFICE  
UK OFFICE

### U.S.A.

#### CKD USA CORPORATION

##### ● CHICAGO HEADQUARTERS

4080 Winnetka Avenue, Rolling Meadows, IL 60008, USA  
PHONE +1-847-368-0539 FAX +1-847-788-0575  
CINCINNATI OFFICE  
SAN ANTONIO OFFICE  
SAN JOSE OFFICE  
DETROIT OFFICE

### Mexico

#### CKD MEXICO, S. DE R.L. DE C.V.

Cerrada la Noria No. 200 Int. A-01, Querétaro Park II,  
Parque Industrial Querétaro, Santa Rosa Jáuregui,  
Querétaro, C.P. 76220, México  
PHONE +52-442-161-0624

### Malaysia

#### M-CKD PRECISION SDN.BHD.

##### ● HEAD OFFICE

Lot No.6,Jalan Modal 23/2, Seksyen 23, Kawasan MIEL,  
Fasa 8, 40300 Shah Alam,Selangor Darul Ehsan, Malaysia  
PHONE +60-(0)3-5541-1468 FAX +60-(0)3-5541-1533  
JOHOR BAHRU BRANCH OFFICE  
PENANG BRANCH OFFICE

### Thailand

#### CKD THAI CORPORATION LTD.

##### ● SALES HEADQUARTERS

Suwan Tower, 14/1 Soi Saladaeng 1, North Sathorn Road,  
Kwaeng Silom, Khet Bangrak, Bangkok 10500, Thailand  
PHONE +66-(0)2-267-6300 FAX +66-(0)2-267-6305  
RAYONG OFFICE  
NAVANAKORN OFFICE  
EASTERN SEABOARD OFFICE  
LAMPHUN OFFICE  
KORAT OFFICE  
AMATANAKORN OFFICE  
PRACHINBURI OFFICE  
SARABURI OFFICE

- 2-250, Ouji, Komaki City, Aichi, 485-8551 Japan
- PHONE+81-(0)568-74-1338 FAX +81-(0)568-77-3461

### Singapore

#### CKD SINGAPORE PTE. LTD.

No.33 Tannery Lane #04-01 Hoesteel Industrial  
Building, Singapore 347789, Singapore  
PHONE +65-67442623 FAX +65-67442486

#### CKD CORPORATION BRANCH OFFICE

No.33 Tannery Lane #04-01 Hoesteel Industrial  
Building, Singapore 347789, Singapore  
PHONE +65-67447260 FAX +65-68421022

### India

#### CKD INDIA PRIVATE LTD.

Unit No. 607, 6th Floor, Welldone Tech Park, Sector 48,  
Sohna Road, Gurgaon-122018, Haryana, India  
PHONE +91-(0)124-418-8212

#### CKD INDIA PRIVATE LTD. BANGALORE BRANCH

No. 201/B, 2nd Floor, Museum Terraces Apartment, No. 29,  
Museum Road, Bangalore-560001, Karnataka, India  
PHONE +91-(0)80-4212-7008/7009 FAX +91-(0)80-4212-7007

### Indonesia

#### PT CKD TRADING INDONESIA

##### ● SALES HEADQUARTERS

Menara Bidakara 2, 18th Floor, Jl. Jend. Gatot Subroto Kav.  
71-73, Pancoran, Jakarta 12870, Indonesia  
PHONE +62 21-2938-6601 FAX +62 21-2906-9470  
SURABAYA OFFICE

### Vietnam

#### CKD VIETNAM ENGINEERING CO.,LTD.

18th Floor, CMC Tower, Duy Tan Street, Cau Giay  
District, Hanoi, Vietnam  
PHONE +84-4-37957631 FAX +84-4-37957637

### Taiwan

#### TAIWAN CKD CORPORATION

16F-3, No. 7, Sec. 3, New Taipei Blvd., Xinzhuang Dist.,  
New Taipei City 242, Taiwan  
PHONE +886-(0)2-8522-8198 FAX +886-(0)2-8522-8128

- HSINCHU OFFICE
- TAICHUNG OFFICE
- TAINAN OFFICE

### China

#### CKD(SHANGHAI)CORPORATION

##### ● SALES HEADQUARTERS / SHANGHAI PUXI OFFICE

Room 601, 6th Floor, Yuanzhongkeyan Building, No. 1905  
Hongmei Road, Xinhui District, Shanghai 200233, China  
PHONE +86-(0)21-61911888 FAX +86-(0)21-60905356

- SHANGHAI PUDONG OFFICE
- WUXI OFFICE
- HANGZHOU OFFICE
- NINGBO OFFICE
- NANJING OFFICE
- SUZHOU OFFICE
- KUNSHAN OFFICE
- BEIJING OFFICE
- TIANJIN OFFICE
- CHANGCHUN OFFICE
- DALIAN OFFICE
- QINGDAO OFFICE
- JINAN OFFICE
- YANTAI OFFICE
- SHENYANG OFFICE
- CHONGQING OFFICE
- CHENGDU OFFICE
- XIAN OFFICE
- WUHAN OFFICE
- ZHENGZHOU OFFICE
- CHANGSHA OFFICE
- GUANGZHOU OFFICE
- WEST SHENZHEN OFFICE
- EAST SHENZHEN OFFICE
- DONGGUAN OFFICE
- XIAMEN OFFICE

### Korea

#### CKD KOREA CORPORATION

##### ● HEADQUARTERS

(3rd Floor), 44, Sinsu-ro, Mapo-gu, Seoul 121-856, Korea  
PHONE +82-(0)2-783-5201~5203 FAX +82-(0)2-783-5204

- SUWON OFFICE
- CHEONAN OFFICE
- ULSAN OFFICE

The goods and/or their replicas, the technology and/or software found in this catalog are subject to complementary export regulations by Foreign Exchange and Foreign Trade Law of Japan.

If the goods and/or their replicas, the technology and/or software found in this catalog are to be exported, law requires that the exporter makes sure that they will never be used for the development and/or manufacture of weapons for mass destruction.